

0804.0003 - EVACUATORE PNEUMATICO

PNEUMATIC EJECTORS / PNEUMATISCHE TEILEFÖRDER / ÉVACUATEUR PNEUMATIQUE

Direzione di avanzamento / Direction of travel
Transportrichtung / Direction d'avancement

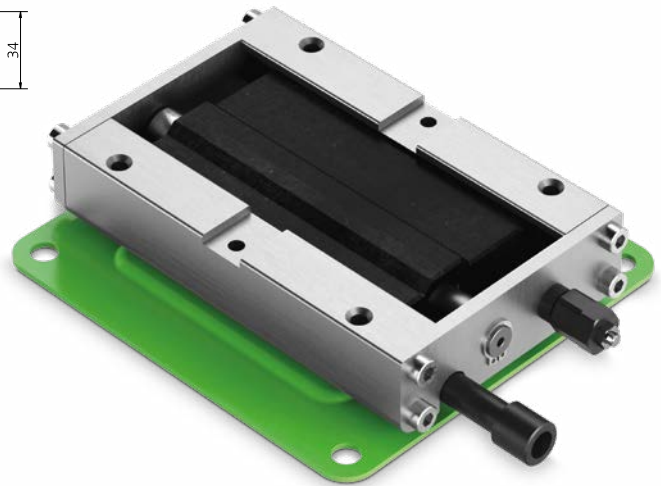
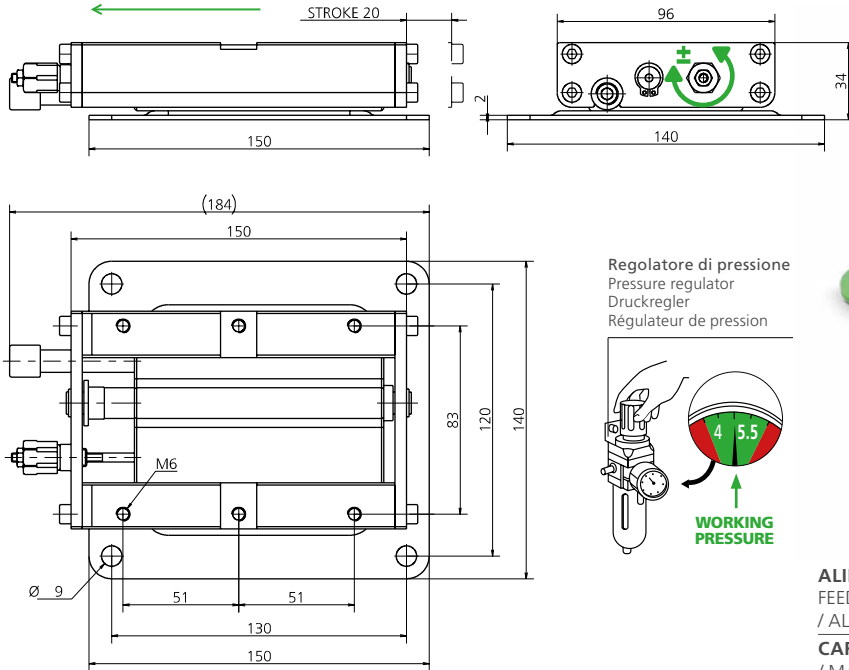

ALIMENTAZIONE AD ARIA COMPRESSA FEED AIR COMPRESSED / SPEISUNG MIT PRESSLUFT / ALIMENTATION À AIR COMPRIMÉ	4/5.5 BAR
CARICO MASSIMO / MAXIMUM LOAD / MAXIMALE BELASTUNG/ CHARGE MAXIMALE	3 kg
CONSUMO D'ARIA /AIR CONSUMPTION / LUFTVERBRAUCH/ CONSOMMATION D'AIR	0,55 l/min
RUMORE / NOICE/ GERÄUSCH/ BRUIT	68 db-A

CODE	DESCRIPTION	Q.TY
8107.0803.0003.001	KIT RICAMBI / REPAIR KIT	*1 OPTION

MODELLO D'ORDINE / ORDER EXAMPLE / BESTELLBEISPIEL / MODÈLE DE COMMANDE

MODEL **0804** MAX LOAD **0003** OPTION CODE **9026.001**

0804.0010 - EVACUATORE PNEUMATICO

PNEUMATIC EJECTORS / PNEUMATISCHE TEILEFÖRDER / ÉVACUATEUR PNEUMATIQUE

Direzione di avanzamento / Direction of travel
Transportrichtung / Direction d'avancement

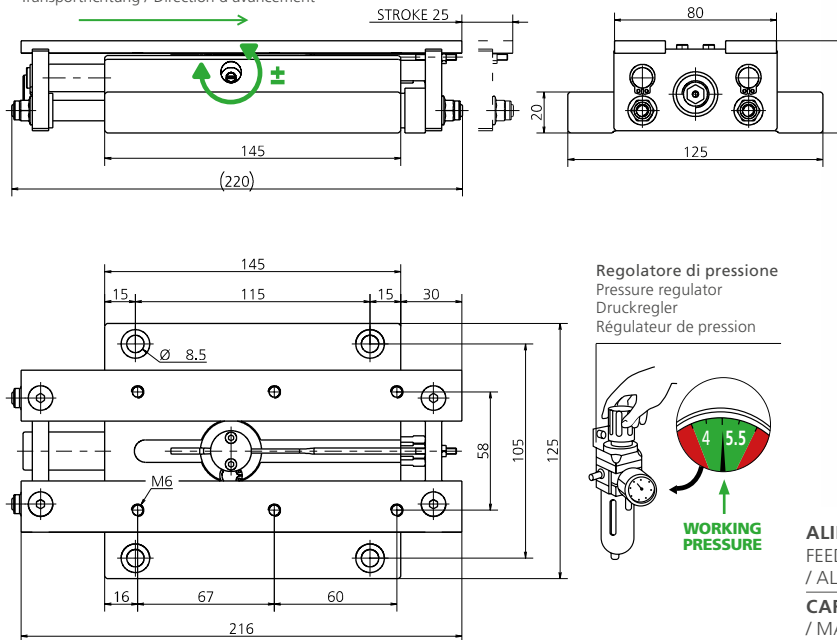

ALIMENTAZIONE AD ARIA COMPRESSA FEED AIR COMPRESSED / SPEISUNG MIT PRESSLUFT / ALIMENTATION À AIR COMPRIMÉ	4/5.5 BAR
CARICO MASSIMO / MAXIMUM LOAD / MAXIMALE BELASTUNG/ CHARGE MAXIMALE	10 kg
CONSUMO D'ARIA /AIR CONSUMPTION / LUFTVERBRAUCH/ CONSOMMATION D'AIR	1.25 l/min
RUMORE / NOICE/ GERÄUSCH/ BRUIT	68 db-A

CODE	DESCRIPTION	Q.TY
8107.0803.0010.001	KIT RICAMBI / REPAIR KIT	*1 OPTION

MODELLO D'ORDINE / ORDER EXAMPLE / BESTELLBEISPIEL / MODÈLE DE COMMANDE

MODEL **0804** MAX LOAD **0010** OPTION CODE **9026.001**

0804.0040 - EVACUATORE PNEUMATICO

PNEUMATIC EJECTORS / PNEUMATISCHE TEILEFÖRDER / ÉVACUATEUR PNEUMATIQUE

Direzione di avanzamento / Direction of travel
Transportrichtung / Direction d'avancement

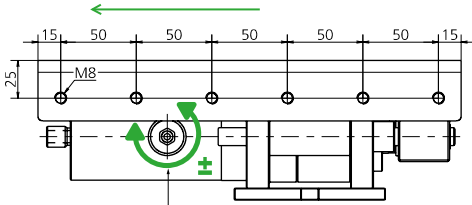

SPEED REGULATOR

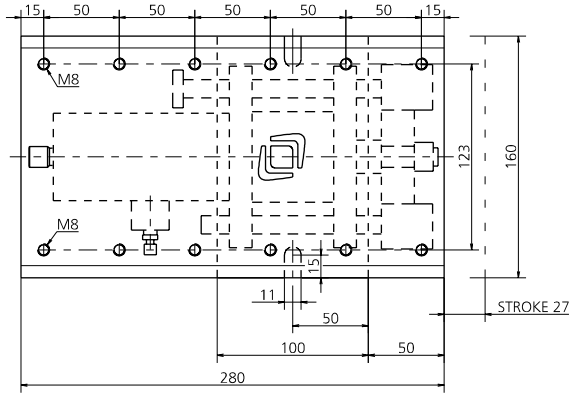
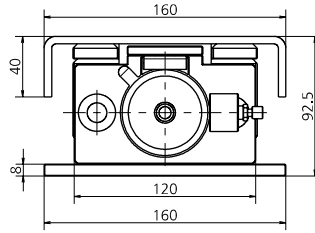

CODE	DESCRIPTION	Q.TY
8107.0803.0040.001	KIT RICAMBI / REPAIR KIT	*1 OPTION

Regolatore di pressione
Pressure regulator
Druckregler
Régulateur de pression

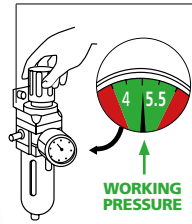

WORKING PRESSURE

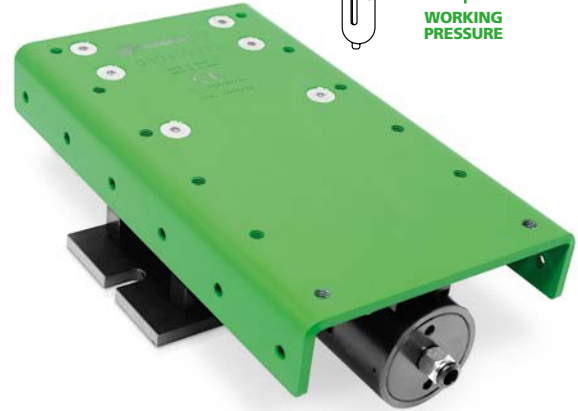

ALIMENTAZIONE AD ARIA COMPRESSA FEED AIR COMPRESSED / SPEISUNG MIT PRESSLUFT / ALIMENTATION À AIR COMPRIMÉ	4/5.5 BAR
CARICO MASSIMO / MAXIMUM LOAD / MAXIMALE BELASTUNG/ CHARGE MAXIMALE	40 kg
CONSUMO D'ARIA /AIR CONSUMPTION / LUFTVERBRAUCH/ CONSOMMATION D'AIR	5.42 l/min
RUMORE / NOICE/ GERÄUSCH/ BRUIT	70 db-A

MODELLO D'ORDINE / ORDER EXAMPLE / BESTELLBEISPIEL / MODÈLE DE COMMANDE

MODEL **0804** MAX LOAD **0040** OPTION CODE **9026.001**

0804.0070 - EVACUATORE PNEUMATICO

PNEUMATIC EJECTORS / PNEUMATISCHE TEILEFÖRDER / ÉVACUATEUR PNEUMATIQUE

Direzione di avanzamento / Direction of travel
Transportrichtung / Direction d'avancement

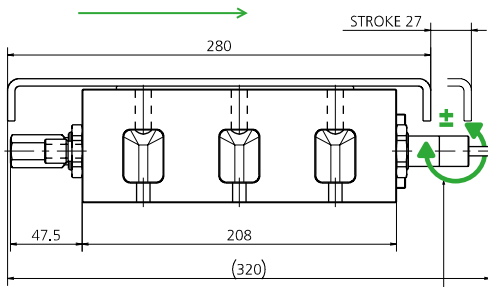

SPEED REGULATOR

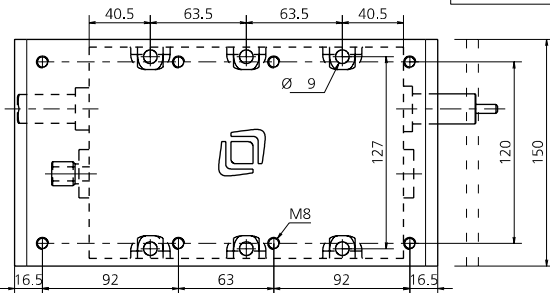
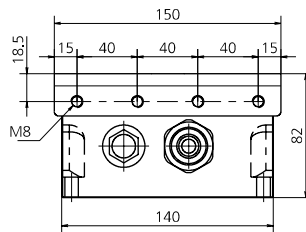

CODE	DESCRIPTION	Q.TY
8107.0803.0070.001	KIT RICAMBI / REPAIR KIT	*1 OPTION

Regolatore di pressione
Pressure regulator
Druckregler
Régulateur de pression

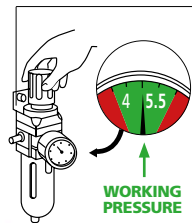

WORKING PRESSURE

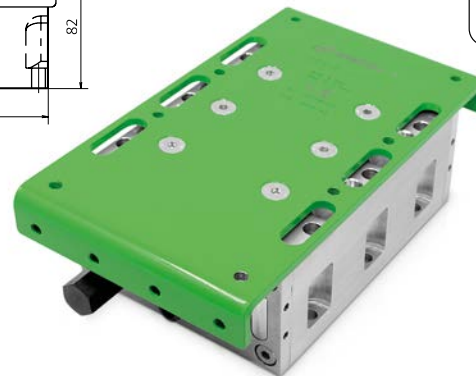

ALIMENTAZIONE AD ARIA COMPRESSA FEED AIR COMPRESSED / SPEISUNG MIT PRESSLUFT / ALIMENTATION À AIR COMPRIMÉ	4/5.5 BAR
CARICO MASSIMO / MAXIMUM LOAD / MAXIMALE BELASTUNG/ CHARGE MAXIMALE	70 kg
CONSUMO D'ARIA /AIR CONSUMPTION / LUFTVERBRAUCH/ CONSOMMATION D'AIR	5.42 l/min
RUMORE / NOICE/ GERÄUSCH/ BRUIT	70 db-A

MODELLO D'ORDINE / ORDER EXAMPLE / BESTELLBEISPIEL / MODÈLE DE COMMANDE

MODEL **0804** MAX LOAD **0070** OPTION CODE **9026.001**