

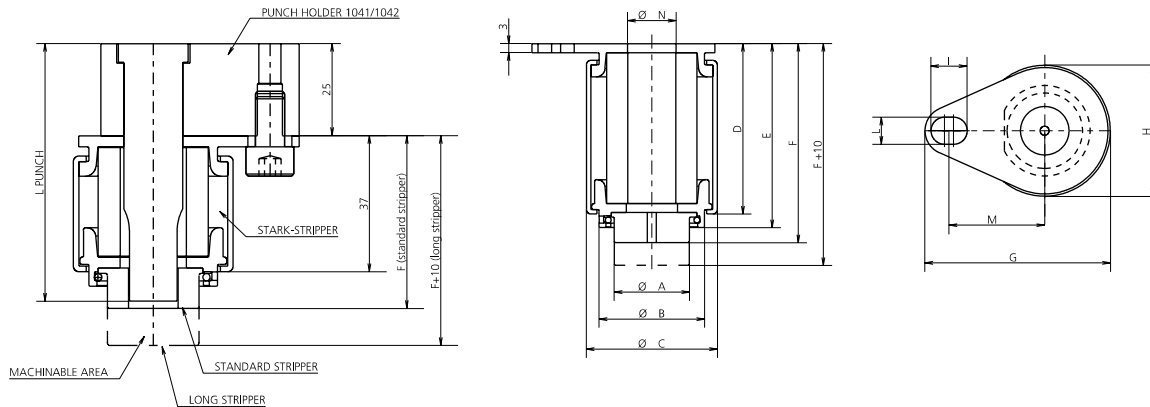

# 1101 - STARK STRIPPERS PER PORTA PUNZONI A TESTA CILINDRICA ISO 8020



## TESTA CILINDRICA / HEADED PUNCHES / ZYLINDRISCHEM KOPF / TÊTE CYLINDRIQUE

MODEL	Ø PUNCH	Ø A	Ø B	Ø C	D	E	F				G	H	I	L	M	Ø N	MAX STROKE	EXTRACTION FORCE daN	
							Pun. L=70/71	Pun. L=80	Pun. L=90	Pun. L=100								F0	F1
1101.0010	10	16	25	33	37	40.5	47	56	66	76	51.5	33	12	9	26.925	10.1	8	20	135
1101.0013	13	20	34	42	37	41	47	56	66	76	59	42	12	9	30	13.1	8	25	230
1101.0016	16	25	39	47.5	37	41	47	56	66	76	63.5	47.5	12	9	31.75	16.1	8	40	300
1101.0020	20	35	45.5	53	37	41.5	47	56	66	76	68	53	12	9	33.5	20.1	8	90	750
1101.0025	25	44	57.5	67	37	42	47	56	66	76	82	67	12	9	40.65	25.1	8	90	1000
1101.0032	32	44	57.5	67	37	42	47	56	66	76	82	67	12	9	40.65	32.1	8	120	800
1101.0040	40	48	65	73.5	37	42.5	47	56	66	76	88.5	73.5	12	9	44	40.1	8	100	700

## COMBINAZIONI D'ORDINE STARK-STRIP + TESTINE / ORDER SCHEMES STARK-STRIP + HEADS MÖGLICHE BESTELLKOMBINATIONEN STARK-STRIP + KÖPFE / COMBINAISONS D'ORDRE STARK-STRIP + TÊTES

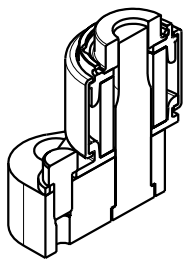

Ø		PUNCH'S LENGTH			
		70/71	80	90	100
10	1101.0010 +	8058.1010.002 (STANDARD STRIPPER)	8058.1020.002 (STANDARD STRIPPER)	8058.1030.002 (STANDARD STRIPPER)	8058.1040.002 (STANDARD STRIPPER)
		8058.1020.001 (LONG STRIPPER)	8058.1030.001 (LONG STRIPPER)	8058.1040.001 (LONG STRIPPER)	8058.1050.002 (LONG STRIPPER)
13	1101.0013 +	8058.1310.002 (STANDARD STRIPPER)	8058.1320.002 (STANDARD STRIPPER)	8058.1330.002 (STANDARD STRIPPER)	8058.1340.002 (STANDARD STRIPPER)
		8058.1320.001 (LONG STRIPPER)	8058.1330.001 (LONG STRIPPER)	8058.1340.001 (LONG STRIPPER)	8058.1350.002 (LONG STRIPPER)
16	1101.0016 +	8058.1610.002 (STANDARD STRIPPER)	8058.1620.002 (STANDARD STRIPPER)	8058.1630.002 (STANDARD STRIPPER)	8058.1640.002 (STANDARD STRIPPER)
		8058.1620.001 (LONG STRIPPER)	8058.1630.001 (LONG STRIPPER)	8058.1640.001 (LONG STRIPPER)	8058.1650.002 (LONG STRIPPER)
20	1101.0020 +	8058.2010.002 (STANDARD STRIPPER)	8058.2020.002 (STANDARD STRIPPER)	8058.2030.002 (STANDARD STRIPPER)	8058.2040.002 (STANDARD STRIPPER)
		8058.2020.001 (LONG STRIPPER)	8058.2030.001 (LONG STRIPPER)	8058.2040.001 (LONG STRIPPER)	8058.2050.002 (LONG STRIPPER)
25	1101.0025 +	8058.2510.002 (STANDARD STRIPPER)	8058.2520.002 (STANDARD STRIPPER)	8058.2530.002 (STANDARD STRIPPER)	8058.2540.002 (STANDARD STRIPPER)
		8058.2520.001 (LONG STRIPPER)	8058.2530.001 (LONG STRIPPER)	8058.2540.001 (LONG STRIPPER)	8058.2550.002 (LONG STRIPPER)
32	1101.0032 +	8058.3210.002 (STANDARD STRIPPER)	8058.3220.002 (STANDARD STRIPPER)	8058.3230.002 (STANDARD STRIPPER)	8058.3240.002 (STANDARD STRIPPER)
		8058.3220.001 (LONG STRIPPER)	8058.3230.001 (LONG STRIPPER)	8058.3240.001 (LONG STRIPPER)	8058.3250.002 (LONG STRIPPER)
40	1101.0040 +	8058.4010.002 (STANDARD STRIPPER)	8058.4020.002 (STANDARD STRIPPER)	8058.4030.002 (STANDARD STRIPPER)	8058.4040.002 (STANDARD STRIPPER)
		8058.4020.001 (LONG STRIPPER)	8058.4030.001 (LONG STRIPPER)	8058.4040.001 (LONG STRIPPER)	8058.4050.002 (LONG STRIPPER)

Per le lavorazioni della testina premilamiera vedere la pagina dedicata "8058 - PREMILAMIERA"

For the machining of the blank holder, see the dedicated page "8058 - BLANK HOLDER" / Für die Vorräsbearbeitung siehe die spezielle Seite "8058 - BLECHPRESSPLATTE".

ESEMPIO DI ORDINE / ORDER EXAMPLE / BESTELLBEISPIEL:

Punzone Ø16 lunghezza 80: Stark stripper 1101.0016 + 8058.1630.002 (se necessarie specificare le lavorazioni come descritto alla pagina dedicata "8058 - PREMILAMIERA")

Punch Ø16 length 80: Stark stripper 1101.0016 + 8058.1630.002 (if necessary, specify the machining as described on the dedicated page "8058 - BLANK HOLDER")

Stempel Ø16 Länge 80: Stark Abstreifer 1101.0016 + 8058.1630.002 (ggf. Bearbeitung angeben, wie auf der entsprechenden Seite "8058 - BLECHPRESSPLATTE" beschrieben)

# 1101 - STARK STRIPPERS PER PORTA PUNZONI BALLOCK LIGHT DUTY

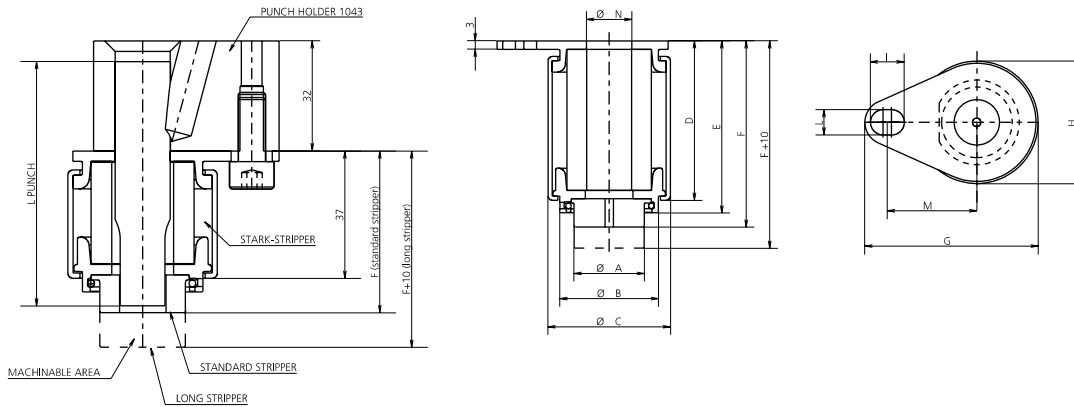

## BALLOCK LIGHT DUTY

MODEL	Ø PUNCH	Ø A	Ø B	Ø C	D	E	F				G	H	I	L	M	Ø N	MAX STROKE	EXTRACTION FORCE daN	
							Pun. L=70/71	Pun. L=80	Pun. L=90	Pun. L=100								F0	F1
1101.0010	10	16	25	33	37	40.5	47	56	66	76	51.5	33	12	9	26.925	10.1	8	20	135
1101.0013	13	20	34	42	37	41	47	56	66	76	59	42	12	9	30	13.1	8	25	230
1101.0016	16	25	39	47.5	37	41	47	56	66	76	63.5	47.5	12	9	31.75	16.1	8	40	300
1101.0020	20	35	45.5	53	37	41.5	47	56	66	76	68	53	12	9	33.5	20.1	8	90	750
1101.0025	25	44	57.5	67	37	42	47	56	66	76	82	67	12	9	40.65	25.1	8	90	1000
1101.0032	32	44	57.5	67	37	42	47	56	66	76	82	67	12	9	40.65	32.1	8	120	800
1101.0040	40	48	65	73.5	37	42.5	47	56	66	76	88.5	73.5	12	9	44	40.1	8	100	700

## COMBINAZIONI D'ORDINE STARK-STRIP + TESTINE / ORDER SCHEMES STARK-STRIP + HEADS MÖGLICHE BESTELLKOMBINATIONEN STARK-STRIP + KÖPFE / COMBINAISONS D'ORDRE STARK-STRIP + TÊTES

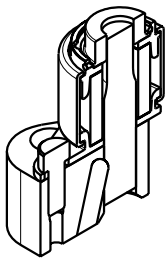

Ø	PUNCH'S LENGTH				
	70/71	80	90	100	
10	1101.0010 +	8058.1010.002 (STANDARD STRIPPER)	8058.1020.002 (STANDARD STRIPPER)	8058.1030.002 (STANDARD STRIPPER)	8058.1040.002 (STANDARD STRIPPER)
		8058.1020.001 (LONG STRIPPER)	8058.1030.001 (LONG STRIPPER)	8058.1040.001 (LONG STRIPPER)	8058.1050.002 (LONG STRIPPER)
13	1101.0013 +	8058.1310.002 (STANDARD STRIPPER)	8058.1320.002 (STANDARD STRIPPER)	8058.1330.002 (STANDARD STRIPPER)	8058.1340.002 (STANDARD STRIPPER)
		8058.1320.001 (LONG STRIPPER)	8058.1330.001 (LONG STRIPPER)	8058.1340.001 (LONG STRIPPER)	8058.1350.002 (LONG STRIPPER)
16	1101.0016 +	8058.1610.002 (STANDARD STRIPPER)	8058.1620.002 (STANDARD STRIPPER)	8058.1630.002 (STANDARD STRIPPER)	8058.1640.002 (STANDARD STRIPPER)
		8058.1620.001 (LONG STRIPPER)	8058.1630.001 (LONG STRIPPER)	8058.1640.001 (LONG STRIPPER)	8058.1650.002 (LONG STRIPPER)
20	1101.0020 +	8058.2010.002 (STANDARD STRIPPER)	8058.2020.002 (STANDARD STRIPPER)	8058.2030.002 (STANDARD STRIPPER)	8058.2040.002 (STANDARD STRIPPER)
		8058.2020.001 (LONG STRIPPER)	8058.2030.001 (LONG STRIPPER)	8058.2040.001 (LONG STRIPPER)	8058.2050.002 (LONG STRIPPER)
25	1101.0025 +	8058.2510.002 (STANDARD STRIPPER)	8058.2520.002 (STANDARD STRIPPER)	8058.2530.002 (STANDARD STRIPPER)	8058.2540.002 (STANDARD STRIPPER)
		8058.2520.001 (LONG STRIPPER)	8058.2530.001 (LONG STRIPPER)	8058.2540.001 (LONG STRIPPER)	8058.2550.002 (LONG STRIPPER)
32	1101.0032 +	8058.3210.002 (STANDARD STRIPPER)	8058.3220.002 (STANDARD STRIPPER)	8058.3230.002 (STANDARD STRIPPER)	8058.3240.002 (STANDARD STRIPPER)
		8058.3220.001 (LONG STRIPPER)	8058.3230.001 (LONG STRIPPER)	8058.3240.001 (LONG STRIPPER)	8058.3250.002 (LONG STRIPPER)
40	1101.0040 +	8058.4010.002 (STANDARD STRIPPER)	8058.4020.002 (STANDARD STRIPPER)	8058.4030.002 (STANDARD STRIPPER)	8058.4040.002 (STANDARD STRIPPER)
		8058.4020.001 (LONG STRIPPER)	8058.4030.001 (LONG STRIPPER)	8058.4040.001 (LONG STRIPPER)	8058.4050.002 (LONG STRIPPER)

Per le lavorazioni della testina premilamiera vedere la pagina dedicata "8058 - PREMILAMIERA"

For the machining of the blank holder, see the dedicated page "8058 - BLANK HOLDER" / Für die Vorräsbearbeitung siehe die spezielle Seite "8058 - BLECHPRESSPLATTE".

ESEMPIO DI ORDINE: / ORDER EXAMPLE: / BESTELLEBEISPIEL:

Punzone Ø20 lunghezza 100: Stark stripper 1101.0020 + 8058.2040.002 (se necessarie specificare le lavorazioni come descritto alla pagina dedicata "8058 - PREMILAMIERA")

Punch Ø20 length 100: Stark stripper 1101.0020 + 8058.2040.002 (if necessary, specify the machining as described on the dedicated page "8058 - BLANK HOLDER")

Stempel Ø20 Länge 100: Stark Abstreifer 1101.0020 + 8058.1240.002 (ggf. Bearbeitung angeben, wie auf der entsprechenden Seite "8058 - BLECHPRESSPLATTE" beschrieben)



# 1101 - STARK STRIPPERS PER PORTA PUNZONI BALLOCK HEAVY DUTY

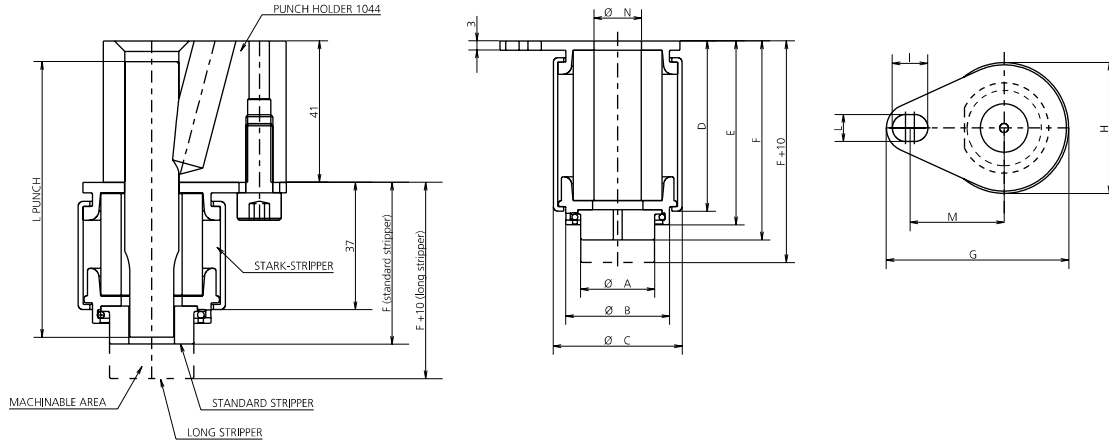

## BALLOCK HEAVY DUTY

MODEL	Ø PUNCH	Ø A	Ø B	Ø C	D	E	F			G	H	I	L	M	Ø N	MAX STROKE	EXTRACTION FORCE daN	
							Pun. L=80	Pun. L=90	Pun. L=100								F0	F1
1101.0010	10	16	25	33	37	40.5	47	56	66	51.5	33	12	9	26.925	10.1	8	20	135
1101.0013	13	20	34	42	37	41	47	56	66	59	42	12	9	30	13.1	8	25	230
1101.0016	16	25	39	47.5	37	41	47	56	66	63.5	47.5	12	9	31.75	16.1	8	40	300
1101.0020	20	35	45.5	53	37	41.5	47	56	66	68	53	12	9	33.5	20.1	8	90	750
1101.0025	25	44	57.5	67	37	42	47	56	66	82	67	12	9	40.65	25.1	8	90	1000
1101.0032	32	44	57.5	67	37	42	47	56	66	82	67	12	9	40.65	32.1	8	120	800
1101.0040	40	48	65	73.5	37	42.5	47	56	66	88.5	73.5	12	9	44	40.1	8	100	700

## COMBINAZIONI D'ORDINE STARK-STRIP + TESTINE / ORDER SCHEMES STARK-STRIP + HEADS MÖGLICHE BESTELLKOMBINATIONEN STARK-STRIP + KÖPFE / COMBINAISONS D'ORDRE STARK-STRIP + TÊTES

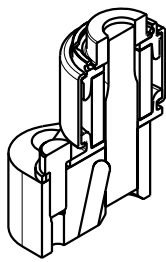

Ø	PUNCH'S LENGTH		
	80	90	100
10	1101.0010 + 8058.1010.002 (STANDARD STRIPPER)	8058.1020.002 (STANDARD STRIPPER)	8058.1030.002 (STANDARD STRIPPER)
	8058.1020.001 (LONG STRIPPER)	8058.1030.001 (LONG STRIPPER)	8058.1040.001 (LONG STRIPPER)
13	1101.0013 + 8058.1310.002 (STANDARD STRIPPER)	8058.1320.002 (STANDARD STRIPPER)	8058.1330.002 (STANDARD STRIPPER)
	8058.1320.001 (LONG STRIPPER)	8058.1330.001 (LONG STRIPPER)	8058.1340.001 (LONG STRIPPER)
16	1101.0016 + 8058.1610.002 (STANDARD STRIPPER)	8058.1620.002 (STANDARD STRIPPER)	8058.1630.002 (STANDARD STRIPPER)
	8058.1620.001 (LONG STRIPPER)	8058.1630.001 (LONG STRIPPER)	8058.1640.001 (LONG STRIPPER)
20	1101.0020 + 8058.2010.002 (STANDARD STRIPPER)	8058.2020.002 (STANDARD STRIPPER)	8058.2030.002 (STANDARD STRIPPER)
	8058.2020.001 (LONG STRIPPER)	8058.2030.001 (LONG STRIPPER)	8058.2040.001 (LONG STRIPPER)
25	1101.0025 + 8058.2510.002 (STANDARD STRIPPER)	8058.2520.002 (STANDARD STRIPPER)	8058.2530.002 (STANDARD STRIPPER)
	8058.2520.001 (LONG STRIPPER)	8058.2530.001 (LONG STRIPPER)	8058.2540.001 (LONG STRIPPER)
32	1101.0032 + 8058.3210.002 (STANDARD STRIPPER)	8058.3220.002 (STANDARD STRIPPER)	8058.3230.002 (STANDARD STRIPPER)
	8058.3220.001 (LONG STRIPPER)	8058.3230.001 (LONG STRIPPER)	8058.3240.001 (LONG STRIPPER)
40	1101.0040 + 8058.4010.002 (STANDARD STRIPPER)	8058.4020.002 (STANDARD STRIPPER)	8058.4030.002 (STANDARD STRIPPER)
	8058.4020.001 (LONG STRIPPER)	8058.4030.001 (LONG STRIPPER)	8058.4040.001 (LONG STRIPPER)

Per le lavorazioni della testina premilamiera vedere la pagina dedicata "8058 - PREMILAMIERA"

For the machining of the blank holder, see the dedicated page "8058 - BLANK HOLDER" / Für die Vorfräsbearbeitung siehe die spezielle Seite "8058 - BLECHPRESSPLATTE".

ESEMPIO DI ORDINE: / ORDER EXAMPLE: / BESTELLBEISPIEL:

Punzone Ø13 lunghezza 90: Stark stripper 1101.0013 + 8058.1320.002 (se necessarie specificare le lavorazioni come descritto alla pagina dedicata "8058 - PREMILAMIERA")

Punch Ø13 length 90: Stark stripper 1101.0013 + 8058.1320.002 (if necessary, specify the machining as described on the dedicated page "8058 - BLANK HOLDER")

Stempel Ø13 Länge 90: Stark Abstreifer 1101.0013 + 8058.1320.002 (ggf. Bearbeitung angeben, wie auf der entsprechenden Seite "8058 - BLECHPRESSPLATTE" beschrieben)

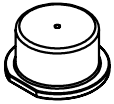

8058..... : Testina premilamiera sbozzata / Blank head / Rohling blechhalterkopf (vedi codici nelle pagine precedenti / see codes on previous pages / siehe Codes auf den vorherigen Seiten)



00T : Testina premilamiera con foratura tonda / Blank holder head with round hole / Rohlingshalterkopf mit rundem Loch (shape X)



00S : Testina premilamiera con foratura sagomata / Blank holder head with shaped hole / Rohlingshalterkopf mit geformtem Loch (shape O-R-H-K-L-J-N-Z-V-Y or special shape)



00T3D : Testina premilamiera con foratura tonda (shape X) e lavorazione 3D / Blank holder head with round drilling (shape X) and 3D machining / Rohlingshalterkopf mit Rundbohrung und 3D-Bearbeitung



00S3D : Testina premilamiera con foratura sagomata (shape O-R-H-K-L-J-N-Z-V-Y or special shape) e lavorazione 3D / Blank holder head with shaped hole and 3D machining / Rohlingshalterkopf mit geformtem Loch und 3D-Bearbeitung

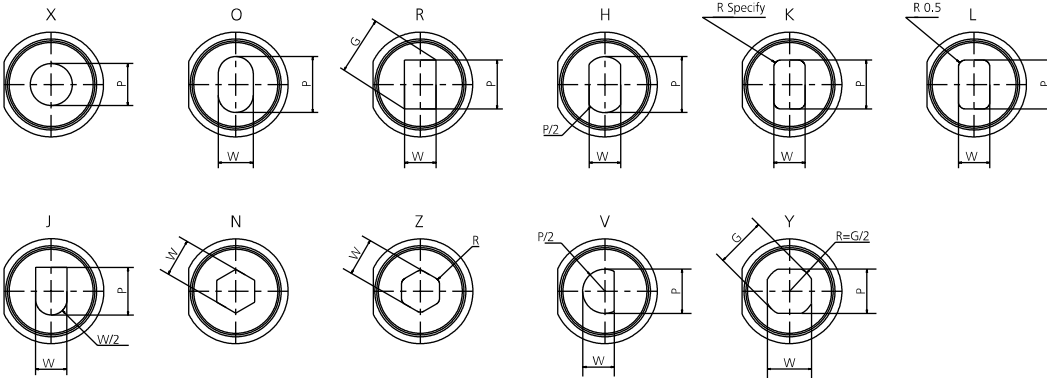

In fase di ordine specificare le misure P/W/R della lavorazione sul premilamiera, non del punzone.  
When ordering, specify the P/W/R measurements of the machining on the blank holder, not of the punch.  
Geben Sie bei der Bestellung die P/W/R-Maße des Werkstücks am Niederhalter an, nicht die des Stempels.

In caso di sagome speciali e lavorazioni 3D è necessario un file del cliente per eseguire le lavorazioni.  
In the case of special shapes and 3D machining, a customer file is required to perform the machining.  
Bei Sonderformen und 3D-Bearbeitungen ist eine Kundendatei erforderlich, um die Bearbeitung durchzuführen.

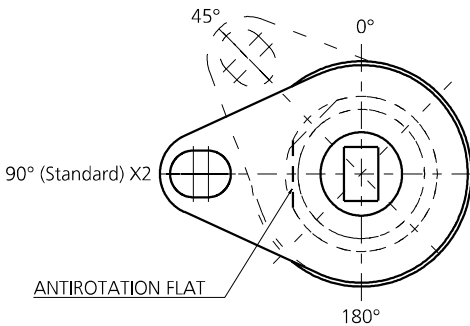

Specificare l'angolo per la lavorazione  
Specify the angle for machining  
Winkel für die Bearbeitung angeben

**ESEMPIO DI ORDINE / ORDER EXAMPLE / BESTELLBEISPIEL:**

1. Punzone ISO 8020 Ø25 lunghezza 80 con premilamiera sbozzato standard / Punch ISO 8020 Ø25 length 80 with standard blank holder  
Stanzen Sie ISO 8020 Ø25 Länge 80 mit Standard-Blechhalter: 1101.0025 + 8058.2520.002
2. Punzone ISO 8020 Ø25 lunghezza 80 con premilamiera sbozzato lungo / Punch ISO 8020 Ø25 length 80 with long blank holder  
Stanzen Sie ISO 8020 Ø25 Länge 80 mit langem Niederhalter: 1101.0025 + 8058.2530.001
3. Punzone ISO 8020 Ø25 lunghezza 80 con premilamiera sagoma "O" standard / Punch ISO 8020 Ø25 length 80 with standard "O" shape blank holder  
Stanzen Sie ISO 8020 Ø25, Länge 80, mit Standard-Blechhalter in „O“-Form: 1101.0025 + 8058.250.002 (00S shape "O" P=22 W=15 X2)