

0151.6019 - CAM SUPER-SMEG6019

FORZA INIZIALE DI ESTRAZIONE / INITIAL EXTRACTION FORCE **6000 daN**

RÜCKZUGSKRAFT / FORCE INITIALE D'EXTRACTION

FORZA FINALE DI ESTRAZIONE / FINAL FORCE OF EXTRACTION **9400 daN**

ENDKRAFT DER EXTRAKTION / FORCE FINALE D'EXTRACTION

SFORZO MAX TRANCIO **60000 daN**

CUTTING MAX FORCE

MAXIMALE SCHNITTKRAFT

EFFORT MAXI DÉCOUPE

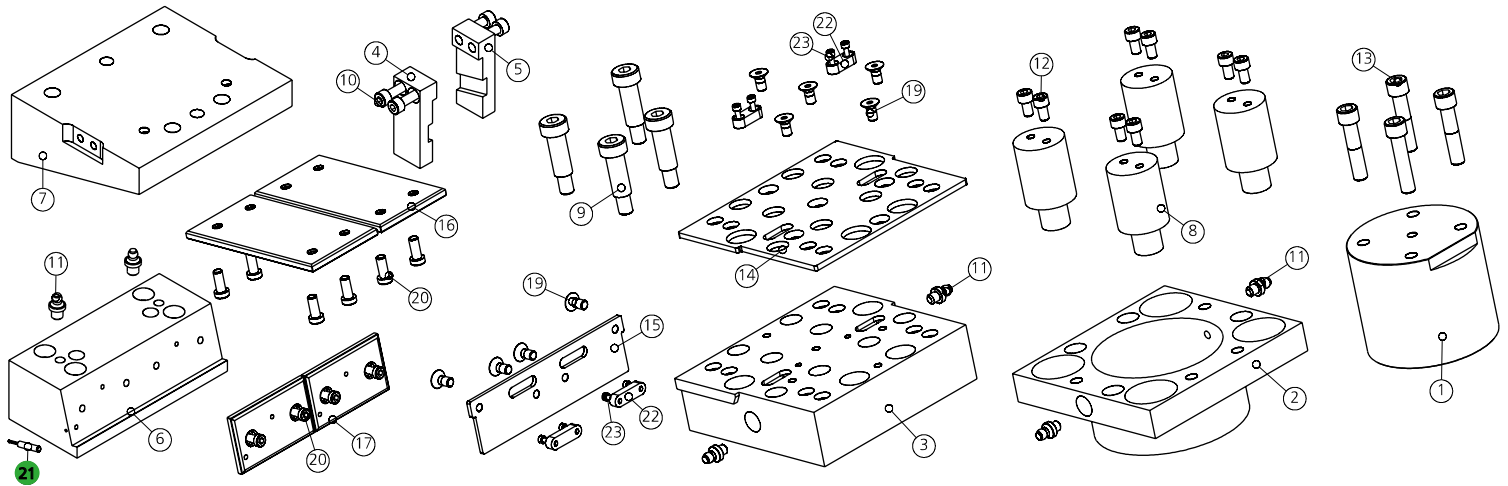

POS.	CODE	DESCRIPTION	Q.TY
001	8018.1100.0000.A90.001	PERNO CENTRALE / CENTRAL PIN / HAUPTSTIFT	1
002	8013.0790.2300.A90.001	BOCCOLA DI GUIDA / GUIDE BUSHINGS / FÜHRUNGSBUCHSE	1
003	8014.0051.6019	PORTA PUNZONE / PUNCHES HOLDER / TRÄGERPLATTE	1
004	8115.0051.0019.05.001	STAFFA DI AGGANCIAMENTO / BRACKET ATTACHMENTS / BRACKETBEFESTIGUNG 5°	1*CHOOSE
004	8115.0051.0019.10.001	STAFFA DI AGGANCIAMENTO / BRACKET ATTACHMENTS / BRACKETBEFESTIGUNG 10°	1*CHOOSE
004	8115.0051.0019.15.001	STAFFA DI AGGANCIAMENTO / BRACKET ATTACHMENTS / BRACKETBEFESTIGUNG 15°	1*CHOOSE
004	8115.0051.0019.20.001	STAFFA DI AGGANCIAMENTO / BRACKET ATTACHMENTS / BRACKETBEFESTIGUNG 20°	1*CHOOSE
004	8115.0051.0019.25.001	STAFFA DI AGGANCIAMENTO / BRACKET ATTACHMENTS / BRACKETBEFESTIGUNG 25°	1*CHOOSE
004	8115.0051.0019.30.001	STAFFA DI AGGANCIAMENTO / BRACKET ATTACHMENTS / BRACKETBEFESTIGUNG 30°	1*CHOOSE
004	8115.0051.0019.35.001	STAFFA DI AGGANCIAMENTO / BRACKET ATTACHMENTS / BRACKETBEFESTIGUNG 35°	1*CHOOSE
004	8115.0051.0019.40.001	STAFFA DI AGGANCIAMENTO / BRACKET ATTACHMENTS / BRACKETBEFESTIGUNG 40°	1*CHOOSE
004	8115.0051.0019.45.001	STAFFA DI AGGANCIAMENTO / BRACKET ATTACHMENTS / BRACKETBEFESTIGUNG 45°	1*CHOOSE
004	8115.0051.0019.50.001	STAFFA DI AGGANCIAMENTO / BRACKET ATTACHMENTS / BRACKETBEFESTIGUNG 50°	1*CHOOSE
005	8115.0051.0019.05.002	STAFFA DI AGGANCIAMENTO / BRACKET ATTACHMENTS / BRACKETBEFESTIGUNG 5°	1*CHOOSE
005	8115.0051.0019.10.002	STAFFA DI AGGANCIAMENTO / BRACKET ATTACHMENTS / BRACKETBEFESTIGUNG 10°	1*CHOOSE
005	8115.0051.0019.15.002	STAFFA DI AGGANCIAMENTO / BRACKET ATTACHMENTS / BRACKETBEFESTIGUNG 15°	1*CHOOSE
005	8115.0051.0019.20.002	STAFFA DI AGGANCIAMENTO / BRACKET ATTACHMENTS / BRACKETBEFESTIGUNG 20°	1*CHOOSE
005	8115.0051.0019.25.002	STAFFA DI AGGANCIAMENTO / BRACKET ATTACHMENTS / BRACKETBEFESTIGUNG 25°	1*CHOOSE
005	8115.0051.0019.30.002	STAFFA DI AGGANCIAMENTO / BRACKET ATTACHMENTS / BRACKETBEFESTIGUNG 30°	1*CHOOSE
005	8115.0051.0019.35.002	STAFFA DI AGGANCIAMENTO / BRACKET ATTACHMENTS / BRACKETBEFESTIGUNG 35°	1*CHOOSE
005	8115.0051.0019.40.002	STAFFA DI AGGANCIAMENTO / BRACKET ATTACHMENTS / BRACKETBEFESTIGUNG 40°	1*CHOOSE
005	8115.0051.0019.45.002	STAFFA DI AGGANCIAMENTO / BRACKET ATTACHMENTS / BRACKETBEFESTIGUNG 45°	1*CHOOSE
005	8115.0051.0019.50.002	STAFFA DI AGGANCIAMENTO / BRACKET ATTACHMENTS / BRACKETBEFESTIGUNG 50°	1*CHOOSE
006	8117.0051.0019.05.001	GUIDA / GUIDE / FÜHRUNG 5°	1*CHOOSE
006	8117.0051.0019.10.001	GUIDA / GUIDE / FÜHRUNG 10°	1*CHOOSE

POS.	CODE	DESCRIPTION	Q.TY
006	8117.0051.0019.15.001	GUIDA / GUIDE / FÜHRUNG 15°	1*CHOOSE
006	8117.0051.0019.20.001	GUIDA / GUIDE / FÜHRUNG 20°	1*CHOOSE
006	8117.0051.0019.25.001	GUIDA / GUIDE / FÜHRUNG 25°	1*CHOOSE
006	8117.0051.0019.30.001	GUIDA / GUIDE / FÜHRUNG 30°	1*CHOOSE
006	8117.0051.0019.35.001	GUIDA / GUIDE / FÜHRUNG 35°	1*CHOOSE
006	8117.0051.0019.40.001	GUIDA / GUIDE / FÜHRUNG 40°	1*CHOOSE
006	8117.0051.0019.45.001	GUIDA / GUIDE / FÜHRUNG 45°	1*CHOOSE
006	8117.0051.0019.50.001	GUIDA / GUIDE / FÜHRUNG 50°	1*CHOOSE
007	8116.0051.0019.05.001	INCUDINE / ANVIL / TREIBER 5°	1*CHOOSE
007	8116.0051.0019.10.001	INCUDINE / ANVIL / TREIBER 10°	1*CHOOSE
007	8116.0051.0019.15.001	INCUDINE / ANVIL / TREIBER 15°	1*CHOOSE
007	8116.0051.0019.20.001	INCUDINE / ANVIL / TREIBER 20°	1*CHOOSE
007	8116.0051.0019.25.001	INCUDINE / ANVIL / TREIBER 25°	1*CHOOSE
007	8116.0051.0019.30.001	INCUDINE / ANVIL / TREIBER 30°	1*CHOOSE
007	8116.0051.0019.35.001	INCUDINE / ANVIL / TREIBER 35°	1*CHOOSE
007	8116.0051.0019.40.001	INCUDINE / ANVIL / TREIBER 40°	1*CHOOSE
007	8116.0051.0019.45.001	INCUDINE / ANVIL / TREIBER 45°	1*CHOOSE
007	8116.0051.0019.50.001	INCUDINE / ANVIL / TREIBER 50°	1*CHOOSE
008	9000.0025.0063.001	CILINDRO AD AZOTO / NITROGEN CYLINDER / STICKSTOFFZYLINDER	4
009	9008.1620.050	VITE A COLLETTA / SHOULDER SCREW / ANSATZSCHRAUBE	4
010	9007.08.040.129.1.4762	VITE / SCREW / SCHRAUBE M8X40	4
011	9006.002	INGRASSATORE / NIPPLES / SCHMIERUNG	6
012	9007.08.010.129.1.4762	VITE / SCREW / SCHRAUBE M8X10	8
013	9007.16.070.129.1.4762	VITE / SCREW / SCHRAUBE M16X70	4
014	8030.2910.2720.048.001	PIASTRINA / PLATE / PLATTE	1
015	8030.2910.0660.048.001	PIASTRINA / PLATE / PLATTE	1
016	9012.2500.1000.100.001	PIASTRA DI SCORRIMENTO / WEAR PLATE / DRUCKPLATTE	2
017	8012.1250.0750.100.001	PIASTRA DI SCORRIMENTO / WEAR PLATE / DRUCKPLATTE	2
019	9007.08.016.129.1.5933	VITE / SCREW / SCHRAUBE M8X16	9
020	9007.10.020.129.1.9327	VITE / SCREW / SCHRAUBE M10X20	12
021	9003.0001	SENSORE DI SICUREZZA / SECURITY SENSOR / SENSOR FÜR SICHERHEIT	1*OPTION
022	8087.0450.0120.080.001	CHIAVETTA / KEY / SCHLÜSSEL	4
023	9007.04.010.129.1.4762	VITE / SCREW / SCHRAUBE M4X10	8

FORZA INIZIALE DI ESTRAZIONE / INITIAL EXTRACTION FORCE **6000 daN** SFORZO MAX TRANCIO **60000 daN**
 RÜCKZUGSKRAFT / FORCE INITIALE D'EXTRACTION
 FORZA FINALE DI ESTRAZIONE / FINAL FORCE OF EXTRACTION **9400 daN** CUTTING MAX FORCE
 ENDKRAFT DER EXTRAKTION / FORCE FINALE D'EXTRACTION MAXIMALE SCHNITTKRAFT
 EFFORT MAXI DÉCOUPE

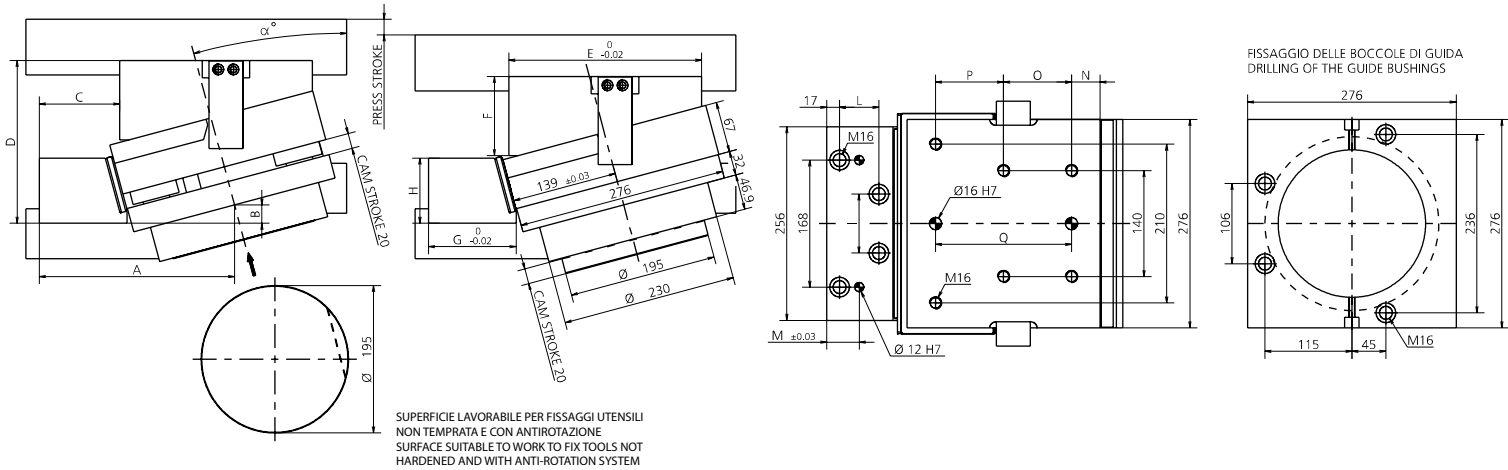

α°	PRESS STROKE	A	B	C	D	E	F	G	H	I	L	M	N	O	P	Q
5°	20.1	247.1	1.4	106.25	186.5	265	76	105	96	168	52	43	42.5	90	90	180
10°	20.3	258.35	18.4	110.5	201.65	265	86	116	96	168	52	43	42.5	90	90	180
15°	20.7	258.35	24.4	106.5	215.35	255	105	116	86	168	52	43	37.5	90	90	180
20°	21.3	266.85	38.4	108	235.1	245	125	126	86	168	52	43	32.5	90	90	180
25°	22.05	264.35	53.4	96.5	248.6	246	136	126	86	168	52	43	33	90	90	180
30°	23.1	261.85	68.4	86	270.65	245	156	126	86	168	52	43	32.5	90	90	180
35°	24.4	255.85	83.4	75	290.95	235	175	126	86	78	41	58	27.5	90	90	180
40°	26.1	250.85	90.4	73	306.65	216	195	126	76	78	37	54	33	75	75	150
45°	28.3	243.85	101.4	64	314.85	205	205	126	76	78	27	44	27.5	75	75	150
50°	31.1	236.85	108.4	62	324.65	185	216	126	67	78	27	44	17.5	75	75	150

* PER INCLINAZIONI FUORI STANDARD RIVOLGERSI ALL'UFFICIO TECNICONESTARK / * FOR NON-STANDARD INCLINATIONS, PLEASE CONTACT NEWSTARK TECHNICAL OFFICE.
 / * FÜR NICHT STANDARDMÄSSIGE NEIGUNGEN WENDEN SIE SICH BITTE AN DAS TECHNISCHE BÜRO VON NEWSTARK

021 (9003) SENSORE / SENSOR / SENSOR



21 PATENT PENDING