

0151.3011 - CAM SUPER-SMEG3011

FORZA INIZIALE DI ESTRAZIONE / INITIAL EXTRACTION FORCE **3000 daN**

RÜCKZUGSKRAFT / FORCE INITIALE D'EXTRACTION

FORZA FINALE DI ESTRAZIONE / FINAL FORCE OF EXTRACTION **4250 daN**

ENDKRAFT DER EXTRACTION / FORCE FINALE D'EXTRACTION

SFORZO MAX TRANCIO **30000 daN**

CUTTING MAX FORCE

MAXIMALE SCHNITTKRAFT

EFFORT MAXI DÉCOUPE

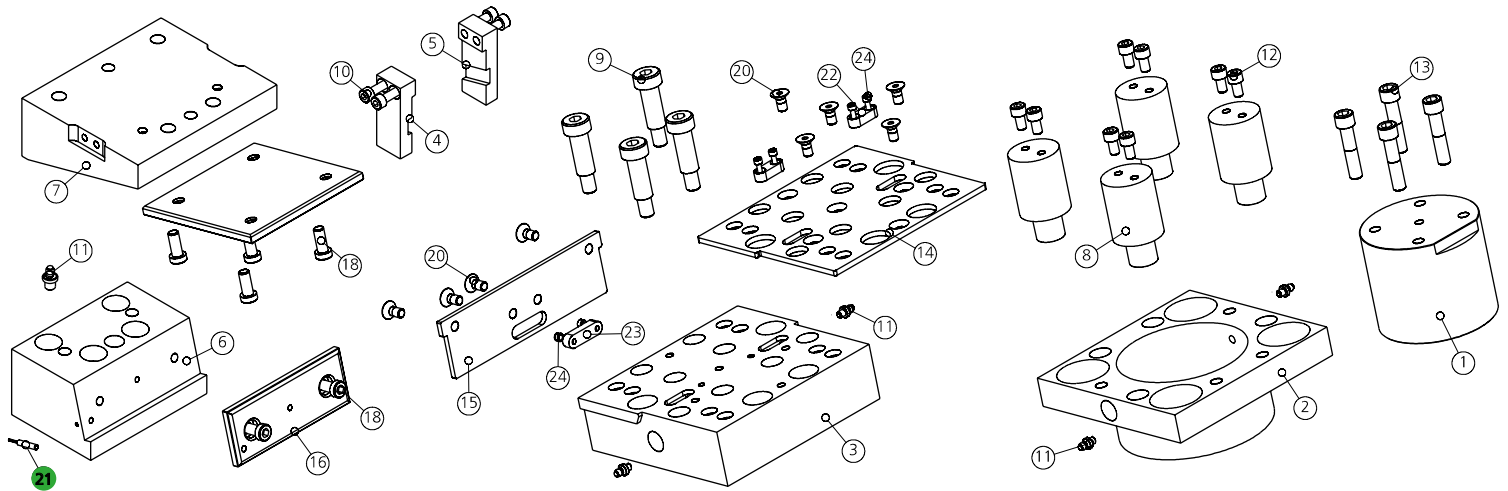

POS.	CODE	DESCRIPTION	Q.TY
001	8018.1000.0000.A10.001	PERNO CENTRALE / CENTRAL PIN / HAUPTSTIFT	1
002	8013.0690.1360.A10.001	BOCCOLA DI GUIDA / GUIDE BUSHINGS / FÜHRUNGSBUCHSE	1
003	8014.0051.3011	PORTA PUNZONE / PUNCHES HOLDER / TRÄGERPLATTE	1
004	8115.4851.3311.05.001	STAFFA DI AGGANCIAMENTO / BRACKET ATTACHMENTS / BRACKETBEFESTIGUNG 5°	1*CHOOSE
004	8115.4851.3311.10.001	STAFFA DI AGGANCIAMENTO / BRACKET ATTACHMENTS / BRACKETBEFESTIGUNG 10°	1*CHOOSE
004	8115.4851.3311.15.001	STAFFA DI AGGANCIAMENTO / BRACKET ATTACHMENTS / BRACKETBEFESTIGUNG 15°	1*CHOOSE
004	8115.4851.3311.20.001	STAFFA DI AGGANCIAMENTO / BRACKET ATTACHMENTS / BRACKETBEFESTIGUNG 20°	1*CHOOSE
004	8115.4851.3311.25.001	STAFFA DI AGGANCIAMENTO / BRACKET ATTACHMENTS / BRACKETBEFESTIGUNG 25°	1*CHOOSE
004	8115.4851.3311.30.001	STAFFA DI AGGANCIAMENTO / BRACKET ATTACHMENTS / BRACKETBEFESTIGUNG 30°	1*CHOOSE
004	8115.4851.3311.35.001	STAFFA DI AGGANCIAMENTO / BRACKET ATTACHMENTS / BRACKETBEFESTIGUNG 35°	1*CHOOSE
004	8115.4851.3311.40.001	STAFFA DI AGGANCIAMENTO / BRACKET ATTACHMENTS / BRACKETBEFESTIGUNG 40°	1*CHOOSE
004	8115.4851.3311.45.001	STAFFA DI AGGANCIAMENTO / BRACKET ATTACHMENTS / BRACKETBEFESTIGUNG 45°	1*CHOOSE
004	8115.4851.3311.50.001	STAFFA DI AGGANCIAMENTO / BRACKET ATTACHMENTS / BRACKETBEFESTIGUNG 50°	1*CHOOSE
005	8115.4851.3311.05.002	STAFFA DI AGGANCIAMENTO / BRACKET ATTACHMENTS / BRACKETBEFESTIGUNG 5°	1*CHOOSE
005	8115.4851.3311.10.002	STAFFA DI AGGANCIAMENTO / BRACKET ATTACHMENTS / BRACKETBEFESTIGUNG 10°	1*CHOOSE
005	8115.4851.3311.15.002	STAFFA DI AGGANCIAMENTO / BRACKET ATTACHMENTS / BRACKETBEFESTIGUNG 15°	1*CHOOSE
005	8115.4851.3311.20.002	STAFFA DI AGGANCIAMENTO / BRACKET ATTACHMENTS / BRACKETBEFESTIGUNG 20°	1*CHOOSE
005	8115.4851.3311.25.002	STAFFA DI AGGANCIAMENTO / BRACKET ATTACHMENTS / BRACKETBEFESTIGUNG 25°	1*CHOOSE
005	8115.4851.3311.30.002	STAFFA DI AGGANCIAMENTO / BRACKET ATTACHMENTS / BRACKETBEFESTIGUNG 30°	1*CHOOSE
005	8115.4851.3311.35.002	STAFFA DI AGGANCIAMENTO / BRACKET ATTACHMENTS / BRACKETBEFESTIGUNG 35°	1*CHOOSE
005	8115.4851.3311.40.002	STAFFA DI AGGANCIAMENTO / BRACKET ATTACHMENTS / BRACKETBEFESTIGUNG 40°	1*CHOOSE
005	8115.4851.3311.45.002	STAFFA DI AGGANCIAMENTO / BRACKET ATTACHMENTS / BRACKETBEFESTIGUNG 45°	1*CHOOSE
005	8115.4851.3311.50.002	STAFFA DI AGGANCIAMENTO / BRACKET ATTACHMENTS / BRACKETBEFESTIGUNG 50°	1*CHOOSE
006	8117.4851.3311.05.001	GUIDA / GUIDE / FÜHRUNG 5°	1*CHOOSE
006	8117.4851.3311.10.001	GUIDA / GUIDE / FÜHRUNG 10°	1*CHOOSE
006	8117.4851.3311.15.001	GUIDA / GUIDE / FÜHRUNG 15°	1*CHOOSE

POS.	CODE	DESCRIPTION	Q.TY
006	8117.4851.3311.20.001	GUIDA / GUIDE / FÜHRUNG 20°	1*CHOOSE
006	8117.4851.3311.25.001	GUIDA / GUIDE / FÜHRUNG 25°	1*CHOOSE
006	8117.4851.3311.30.001	GUIDA / GUIDE / FÜHRUNG 30°	1*CHOOSE
006	8117.4851.3311.35.001	GUIDA / GUIDE / FÜHRUNG 35°	1*CHOOSE
006	8117.4851.3311.40.001	GUIDA / GUIDE / FÜHRUNG 40°	1*CHOOSE
006	8117.4851.3311.45.001	GUIDA / GUIDE / FÜHRUNG 45°	1*CHOOSE
006	8117.4851.3311.50.001	GUIDA / GUIDE / FÜHRUNG 50°	1*CHOOSE
007	8116.4851.3311.05.001	INCUDINE / ANVIL / TREIBER 5°	1*CHOOSE
007	8116.4851.3311.10.001	INCUDINE / ANVIL / TREIBER 10°	1*CHOOSE
007	8116.4851.3311.15.001	INCUDINE / ANVIL / TREIBER 15°	1*CHOOSE
007	8116.4851.3311.20.001	INCUDINE / ANVIL / TREIBER 20°	1*CHOOSE
007	8116.4851.3311.25.001	INCUDINE / ANVIL / TREIBER 25°	1*CHOOSE
007	8116.4851.3311.30.001	INCUDINE / ANVIL / TREIBER 30°	1*CHOOSE
007	8116.4851.3311.35.001	INCUDINE / ANVIL / TREIBER 35°	1*CHOOSE
007	8116.4851.3311.40.001	INCUDINE / ANVIL / TREIBER 40°	1*CHOOSE
007	8116.4851.3311.45.001	INCUDINE / ANVIL / TREIBER 45°	1*CHOOSE
007	8116.4851.3311.50.001	INCUDINE / ANVIL / TREIBER 50°	1*CHOOSE
008	9000.0025.0045.001	CILINDRO AD AZOTO / NITROGEN CYLINDER / STICKSTOFFZYLINDER	4
009	9008.1216.040	VITE A COLLETTA / SHOULDER SCREW / ANSATZSCHRAUBE	4
010	9007.08.030.129.1.4762	VITE / SCREW / SCHRAUBE M8X30	4
011	9006.002	INGRASSATORE / NIPPLES / SCHMIERUNG	5
012	9007.08.010.129.1.4762	VITE / SCREW / SCHRAUBE M8X10	8
013	9007.12.055.129.1.4762	VITE / SCREW / SCHRAUBE M12X55	4
014	8030.1930.1690.048.001	PIASTRINA / PLATE / PLATTE	1
015	8030.1930.0560.048.001	PIASTRINA / PLATE / PLATTE	1
016	8012.1500.0580.100.001	PIASTRA DI SCORRIMENTO / WEAR PLATE / DRUCKPLATTE	1
017	9012.1500.1500.100.001	PIASTRA DI SCORRIMENTO / WEAR PLATE / DRUCKPLATTE	1
018	9007.10.020.129.1.9327	VITE / SCREW / SCHRAUBE M10X20	6
020	9007.08.016.129.1.5933	VITE / SCREW / SCHRAUBE M8X16	9
021	9003.0001	SENSORE DI SICUREZZA / SECURITY SENSOR / SENSOR FÜR SICHERHEIT	1*OPTION
022	8087.0300.0120.080.001	CHIAVETTA / KEY / SCHLÜSSEL	2
023	8087.0400.0120.080.001	CHIAVETTA / KEY / SCHLÜSSEL	1
024	9007.04.010.129.1.4762	VITE / SCREW / SCHRAUBE M4X10	6

FORZA INIZIALE DI ESTRAZIONE / INITIAL EXTRACTION FORCE **3000 daN** SFORZO MAX TRANCIO **30000 daN**
 RÜCKZUGSKRAFT / FORCE INITIALE D'EXTRACTION
 FORZA FINALE DI ESTRAZIONE / FINAL FORCE OF EXTRACTION **4250 daN** CUTTING MAX FORCE
 ENDKRAFT DER EXTRAKTION / FORCE FINALE D'EXTRACTION MAXIMALE SCHNITTKRAFT
 EFFORT MAXI DÉCOUPE

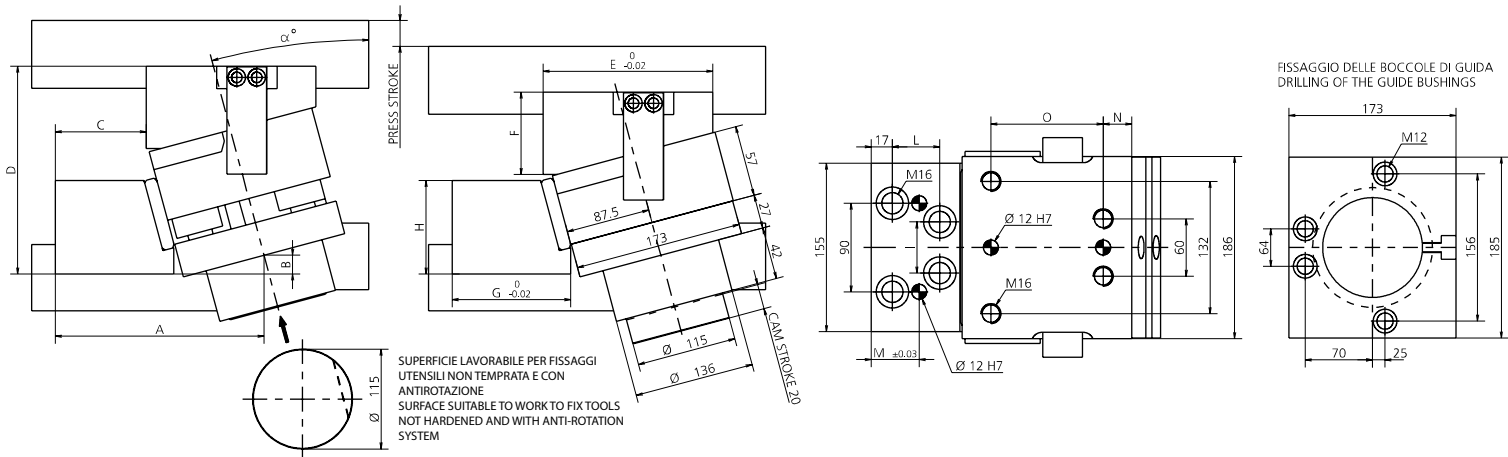

α°	PRESS STROKE	A	B	C	D	E	F	G	H	I	L	M	N
5°	20.1	187.35	77.85	95	142.05	165	46	96	76	56	43	27.5	110
10°	20.3	188.35	68.35	89.5	154.3	165	56	96	76	56	43	27.5	110
15°	20.7	199.35	59.35	99	167.65	155	67	106	76	56	43	22.5	110
20°	21.3	199.35	49.35	90	177.7	155	76	106	76	56	43	22.5	110
25°	22.05	198.35	39.35	81	187.9	155	86	106	75	56	38	22.5	110
30°	23.1	197.35	30.35	71	197.9	155	96	106	75	56	38	22.5	110
35°	24.4	194.85	19.35	66.5	206.55	145	106	106	72	56	33	17.5	110
40°	26.1	202.35	9.35	77.5	216.7	136	116	116	66	56	38	25	86
45°	28.3	188.35	0.35	63.5	229.9	126	126	106	66	40	21.5	20	86
50°	31.1	183.35	-13.65	53.5	243.75	116	146	106	60	40	21.5	15	86

* PER INCLINAZIONI FUORI STANDARD RIVOLGERSI ALL'UFFICIO TECNICONEWSTARK / * FOR NON-STANDARD INCLINATIONS, PLEASE CONTACT NEWSTARK TECHNICAL OFFICE.
 / * FÜR NICHT STANDARDMÄSSIGE NEIGUNGEN WENDEN SIE SICH BITTE AN DAS TECHNISCHE BÜRO VON NEWSTARK

021 (9003) SENSORE / SENSOR / SENSOR



21 PATENT PENDING