

# 0151.0605 - CAM SUPER-SMEG0605

FORZA INIZIALE DI ESTRAZIONE / INITIAL EXTRACTION FORCE **680 daN**  
 RÜCKZUGSKRAFT / FORCE INITIALE D'EXTRACTION  
 FORZA FINALE DI ESTRAZIONE / FINAL FORCE OF EXTRACTION **1030 daN**  
 ENDKRAFT DER EXTRACTION / FORCE FINALE D'EXTRACTION

SFORZO MAX TRANCIO **8000 daN**  
 CUTTING MAX FORCE  
 MAXIMALE SCHNITTKRAFT  
 EFFORT MAXI DÉCOUPE

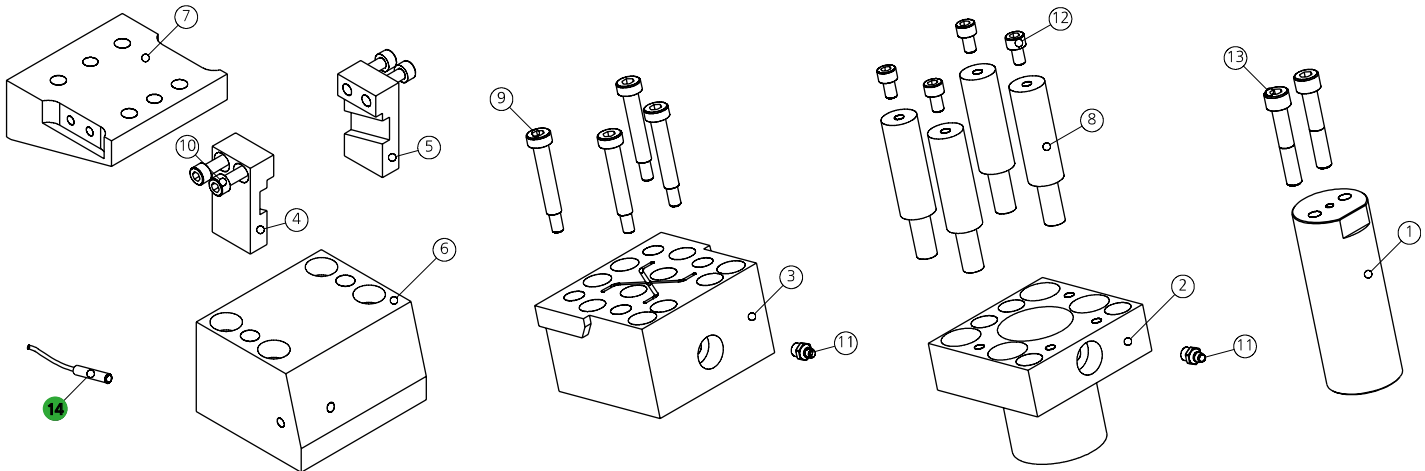

POS.	CODE	DESCRIPTION	Q.TY
001	<b>8018.1000.0000.500.001</b>	PERNO CENTRALE / CENTRAL PIN / HAUPTSTIFT	1
002	<b>8013.0690.0600.500.001</b>	BOCCOLA DI GUIDA / GUIDE BUSHINGS / FÜHRUNGSBUCHSE	1
003	<b>8014.0051.0605</b>	PORTA PUNZONE / PUNCHES HOLDER / TRÄGERPLATTE	1
004	<b>8115.4851.0605.05.001</b>	STAFFA DI AGGANCIAMENTO / BRACKET ATTACHMENTS / BRACKETBEFESTIGUNG 5°	1*CHOOSE
004	<b>8115.4851.0605.10.001</b>	STAFFA DI AGGANCIAMENTO / BRACKET ATTACHMENTS / BRACKETBEFESTIGUNG 10°	1*CHOOSE
004	<b>8115.4851.0605.15.001</b>	STAFFA DI AGGANCIAMENTO / BRACKET ATTACHMENTS / BRACKETBEFESTIGUNG 15°	1*CHOOSE
004	<b>8115.4851.0605.20.001</b>	STAFFA DI AGGANCIAMENTO / BRACKET ATTACHMENTS / BRACKETBEFESTIGUNG 20°	1*CHOOSE
004	<b>8115.4851.0605.25.001</b>	STAFFA DI AGGANCIAMENTO / BRACKET ATTACHMENTS / BRACKETBEFESTIGUNG 25°	1*CHOOSE
004	<b>8115.4851.0605.30.001</b>	STAFFA DI AGGANCIAMENTO / BRACKET ATTACHMENTS / BRACKETBEFESTIGUNG 30°	1*CHOOSE
004	<b>8115.4851.0605.35.001</b>	STAFFA DI AGGANCIAMENTO / BRACKET ATTACHMENTS / BRACKETBEFESTIGUNG 35°	1*CHOOSE
004	<b>8115.4851.0605.40.001</b>	STAFFA DI AGGANCIAMENTO / BRACKET ATTACHMENTS / BRACKETBEFESTIGUNG 40°	1*CHOOSE
004	<b>8115.4851.0605.45.001</b>	STAFFA DI AGGANCIAMENTO / BRACKET ATTACHMENTS / BRACKETBEFESTIGUNG 45°	1*CHOOSE
004	<b>8115.4851.0605.50.001</b>	STAFFA DI AGGANCIAMENTO / BRACKET ATTACHMENTS / BRACKETBEFESTIGUNG 50°	1*CHOOSE
005	<b>8115.4851.0605.05.002</b>	STAFFA DI AGGANCIAMENTO / BRACKET ATTACHMENTS / BRACKETBEFESTIGUNG 5°	1*CHOOSE
005	<b>8115.4851.0605.10.002</b>	STAFFA DI AGGANCIAMENTO / BRACKET ATTACHMENTS / BRACKETBEFESTIGUNG 10°	1*CHOOSE
005	<b>8115.4851.0605.15.002</b>	STAFFA DI AGGANCIAMENTO / BRACKET ATTACHMENTS / BRACKETBEFESTIGUNG 15°	1*CHOOSE
005	<b>8115.4851.0605.20.002</b>	STAFFA DI AGGANCIAMENTO / BRACKET ATTACHMENTS / BRACKETBEFESTIGUNG 20°	1*CHOOSE
005	<b>8115.4851.0605.25.002</b>	STAFFA DI AGGANCIAMENTO / BRACKET ATTACHMENTS / BRACKETBEFESTIGUNG 25°	1*CHOOSE
005	<b>8115.4851.0605.30.002</b>	STAFFA DI AGGANCIAMENTO / BRACKET ATTACHMENTS / BRACKETBEFESTIGUNG 30°	1*CHOOSE
005	<b>8115.4851.0605.35.002</b>	STAFFA DI AGGANCIAMENTO / BRACKET ATTACHMENTS / BRACKETBEFESTIGUNG 35°	1*CHOOSE
005	<b>8115.4851.0605.40.002</b>	STAFFA DI AGGANCIAMENTO / BRACKET ATTACHMENTS / BRACKETBEFESTIGUNG 40°	1*CHOOSE
005	<b>8115.4851.0605.45.002</b>	STAFFA DI AGGANCIAMENTO / BRACKET ATTACHMENTS / BRACKETBEFESTIGUNG 45°	1*CHOOSE

POS.	CODE	DESCRIPTION	Q.TY
005	<b>8115.4851.0605.50.002</b>	STAFFA DI AGGANCIAMENTO / BRACKET ATTACHMENTS / BRACKETBEFESTIGUNG 50°	1*CHOOSE
006	<b>8117.4851.0605.05.001</b>	GUIDA / GUIDE / FÜHRUNG 5°	1*CHOOSE
006	<b>8117.4851.0605.10.001</b>	GUIDA / GUIDE / FÜHRUNG 10°	1*CHOOSE
006	<b>8117.4851.0605.15.001</b>	GUIDA / GUIDE / FÜHRUNG 15°	1*CHOOSE
006	<b>8117.4851.0605.20.001</b>	GUIDA / GUIDE / FÜHRUNG 20°	1*CHOOSE
006	<b>8117.4851.0605.25.001</b>	GUIDA / GUIDE / FÜHRUNG 25°	1*CHOOSE
006	<b>8117.4851.0605.30.001</b>	GUIDA / GUIDE / FÜHRUNG 30°	1*CHOOSE
006	<b>8117.4851.0605.35.001</b>	GUIDA / GUIDE / FÜHRUNG 35°	1*CHOOSE
006	<b>8117.4851.0605.40.001</b>	GUIDA / GUIDE / FÜHRUNG 40°	1*CHOOSE
006	<b>8117.4851.0605.45.001</b>	GUIDA / GUIDE / FÜHRUNG 45°	1*CHOOSE
006	<b>8117.4851.0605.50.001</b>	GUIDA / GUIDE / FÜHRUNG 50°	1*CHOOSE
007	<b>8116.4851.0605.05.001</b>	INCUDINE / ANVIL / TREIBER 5°	1*CHOOSE
007	<b>8116.4851.0605.10.001</b>	INCUDINE / ANVIL / TREIBER 10°	1*CHOOSE
007	<b>8116.4851.0605.15.001</b>	INCUDINE / ANVIL / TREIBER 15°	1*CHOOSE
007	<b>8116.4851.0605.20.001</b>	INCUDINE / ANVIL / TREIBER 20°	1*CHOOSE
007	<b>8116.4851.0605.25.001</b>	INCUDINE / ANVIL / TREIBER 25°	1*CHOOSE
007	<b>8116.4851.0605.30.001</b>	INCUDINE / ANVIL / TREIBER 30°	1*CHOOSE
007	<b>8116.4851.0605.35.001</b>	INCUDINE / ANVIL / TREIBER 35°	1*CHOOSE
007	<b>8116.4851.0605.40.001</b>	INCUDINE / ANVIL / TREIBER 40°	1*CHOOSE
007	<b>8116.4851.0605.45.001</b>	INCUDINE / ANVIL / TREIBER 45°	1*CHOOSE
007	<b>8116.4851.0605.50.001</b>	INCUDINE / ANVIL / TREIBER 50°	1*CHOOSE
008	<b>9000.0025.0019.007</b>	CILINDRO AD AZOTO / NITROGEN CYLINDER / STICKSTOFFZYLINDER	4
009	<b>9008.0608.040</b>	VITE A COLLETO / SHOULDER SCREW / ANSATZSCHRAUBE	4
010	<b>9007.06.020.129.1.4762</b>	VITE / SCREW / SCHRAUBE M6X20	4
011	<b>9006.002</b>	INGRASSATORE / NIPPLES / SCHMIERUNG	2
012	<b>9007.06.010.129.1.4762</b>	VITE / SCREW / SCHRAUBE M6X10	4
013	<b>9007.08.045.129.1.4762</b>	VITE / SCREW / SCHRAUBE M8X45	2
014	<b>9003.0001</b>	SENSORE DI SICUREZZA / SECURITY SENSOR / SENSOR FÜR SICHERHEIT	1*OPTION

# 0151.0605 - CAM SUPER-SMEG0605

PATENT PENDING

FORZA INIZIALE DI ESTRAZIONE / INITIAL EXTRACTION FORCE **680 daN** SFORZO MAX TRANCIO **8000 daN**  
 RÜCKZUGSKRAFT / FORCE INITIALE D'EXTRACTION  
 FORZA FINALE DI ESTRAZIONE / FINAL FORCE OF EXTRACTION **1030 daN** CUTTING MAX FORCE  
 ENDKRAFT DER EXTRAKTION / FORCE FINALE D'EXTRACTION MAXIMALE SCHNITTKRAFT  
 EFFORT MAXI DÉCOUPE

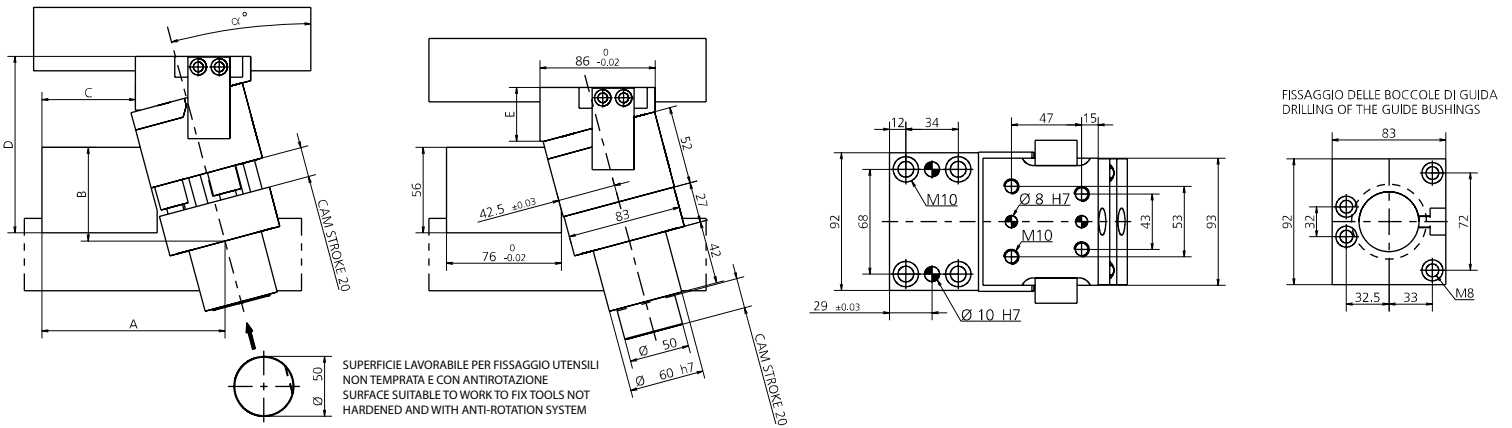

$\alpha^\circ$	PRESS STROKE	A	B	C	D	E
5°	20.1	121.3	72.5	70	107.15	28
10°	20.3	123.65	67.5	64.3	114.5	35
15°	20.7	125.45	62.5	58.15	118.7	38
20°	21.3	126.8	57.5	52.5	125.8	46
25°	22.05	127.25	51.5	45.45	133.4	53
30°	23.1	126	41.8	38.15	140.7	58
35°	24.4	126.2	37.8	31.35	146.2	63
40°	26.1	123.55	30.8	22.7	155.25	71
45°	28.3	127.6	22.5	21.15	161.7	76
50°	31.1	123.6	15.5	14.2	175.2	86

\* PER INCLINAZIONI FUORI STANDARD RIVOLGERSI ALL'UFFICIO TECNICONESTARK / \* FOR NON-STANDARD INCLINATIONS, PLEASE CONTACT NEWSTARK TECHNICAL OFFICE.  
 / \* FÜR NICHT STANDARDMÄSSIGE NEIGUNGEN WENDEN SIE SICH BITTE AN DAS TECHNISCHE BÜRO VON NEWSTARK

014 (9003) SENSORE / SENSOR / SENSOR



14 PATENT PENDING

MODELLO D'ORDINE / ORDER EXAMPLE / BESTELLBEISPIEL / MODÈLE DE COMMANDE

MODEL **0151.0605** INCLINATION **+10°** OPTION CODE **9003.0001**