

0149.K580 - CAM ROLLER K580

FORZA INIZIALE DI ESTRAZIONE / INITIAL EXTRACTION FORCE **500 daN**
 RÜCKZUGSKRAFT / FORCE INITIALE D'EXTRACTION
 FORZA FINALE DI ESTRAZIONE / FINAL FORCE OF EXTRACTION **936 daN**
 ENDKRAFT DER EXTRAKTION / FORCE FINALE D'EXTRACTION

SPORZO MAX TRANCIO **25800 daN**
 CUTTING MAX FORCE
 MAXIMALE SCHNITTKRAFT
 EFFORT MAXI DÉCOUPE

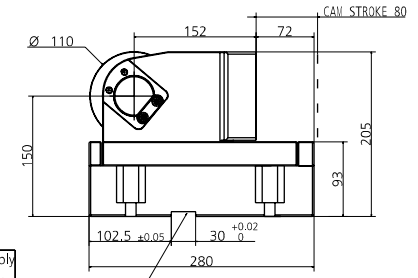
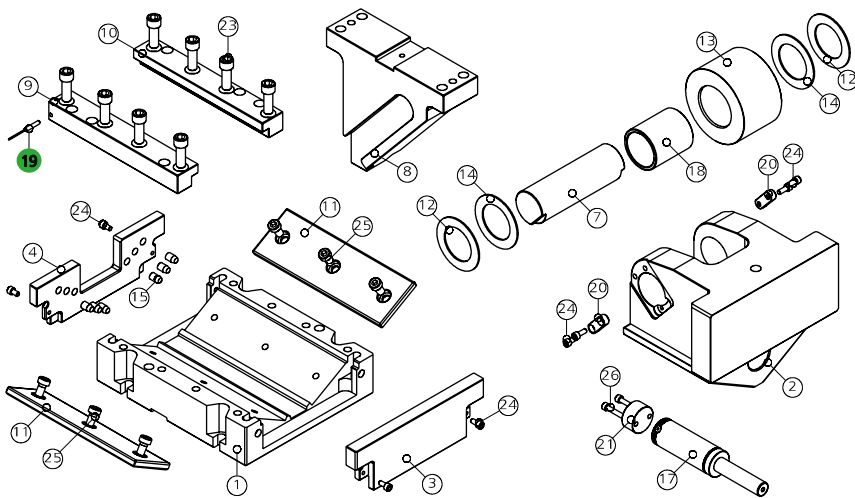

We suggest you to assembly by using a thrust mount key

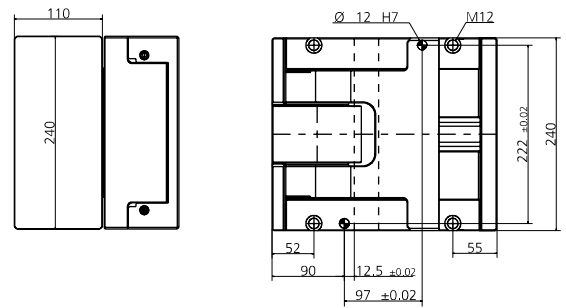

POS.	CODE	DESCRIPTION	Q.TY
001	8000.0049.0580	CORPO CAMMA / CAM BODY / GRUNDGEHÄUSE	1
002	8007.0049.0500	SLITTA / SLIDER / LAGERKEIL	1
003	8088.0049.0500.001	PIASTRINA / PLATE / PLATTE	1
004	8088.0049.0500.002	PIASTRINA / PLATE / PLATTE	1
007	8005.1550.1417.500.001	PERNO / PIN / STIFT	1
008	8090.0405.A080.000	CUNEO / WEDGE / DRUCKSTÜCK 0	1*OPTION
008	8090.0405.A080.605	CUNEO / WEDGE / DRUCKSTÜCK +5	1*OPTION
008	8090.0405.A080.610	CUNEO / WEDGE / DRUCKSTÜCK +10	1*OPTION
008	8090.0405.A080.615	CUNEO / WEDGE / DRUCKSTÜCK +15	1*OPTION
008	8090.0405.A080.705	CUNEO / WEDGE / DRUCKSTÜCK -5	1*OPTION
008	8090.0405.A080.710	CUNEO / WEDGE / DRUCKSTÜCK -10	1*OPTION
008	8090.0405.A080.715	CUNEO / WEDGE / DRUCKSTÜCK -15	1*OPTION
008	8090.0405.A080.720	CUNEO / WEDGE / DRUCKSTÜCK -20	1*OPTION
008	8090.0405.A080.725	CUNEO / WEDGE / DRUCKSTÜCK -25	1*OPTION
008	8090.0405.A080.730	CUNEO / WEDGE / DRUCKSTÜCK -30	1*OPTION
008	8090.0405.A080.735	CUNEO / WEDGE / DRUCKSTÜCK -35	1*OPTION
008	8090.0405.A080.740	CUNEO / WEDGE / DRUCKSTÜCK -40	1*OPTION
008	8090.0405.A080.745	CUNEO / WEDGE / DRUCKSTÜCK -45	1*OPTION
008	8090.0405.A080.750	CUNEO / WEDGE / DRUCKSTÜCK -50	1*OPTION
009	8086.2420.0390.300.001	GUIDA ANGOLARE / SIDE PLATE L / WINKELFÜHRUNG FÜHRUNGSSCHIENE	1
010	8086.2420.0390.300.002	GUIDA ANGOLARE / SIDE PLATE L / WINKELFÜHRUNG FÜHRUNGSSCHIENE	1
011	8012.2400.0750.100.001	PIASTRA DI SCORRIMENTO / WEAR PLATE / DRUCKPLATTE	2
012	8006.0220.0780.505.001	RONDELLA / WASHER / UNTERLEGSCHIBE	2
013	8004.1100.0705.600.001	ROTELLA / ROLLER / ROLLE	1
014	9033.5278.020	RALLA / THRUST WASHER / DRUCKSCHEIBE	2
015	9020.10.15.E090	PUNTALINO / BUMP STOP / DRUCKSTÜCK	6
017	9000.0080.0038.002	CILINDRO AD AZOTO / NITROGEN CYLINDER / STICKSTOFFZYLINDER	1
018	9035.5060.700.001	BOCCOLA / BUSH / BUCHSE	1
019	9003.0002	SENSORE DI SICUREZZA / SECURITY SENSOR / SENSOR FÜR SICHERHEIT	1*OPTION
020	8087.0400.0140.090.001	CHIAVETTA / KEY / SCHLÜSSEL	2
021	8089.0388.0200.001	DISTANZIALE / SPACER / ABSTANDSHALTER	1
023	9007.12.035.129.1.4762	VITE / SCREW / SCHRAUBE M12X35	8
024	9007.06.012.129.1.4762	VITE / SCREW / SCHRAUBE M6X12	8
025	9007.10.020.129.1.9327	VITE / SCREW / SCHRAUBE M10X20	6
026	9007.06.045.129.1.4762	VITE / SCREW / SCHRAUBE M6X45	2

POSSIBILI INCLINAZIONI / POSSIBLE INCLINATIONS / MÖGLICHE NEIGUNGEN

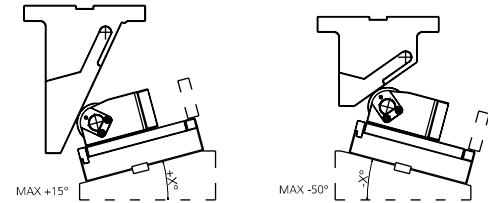

008 (8090) CUNEO / WEDGE / DRUCKSTÜCK

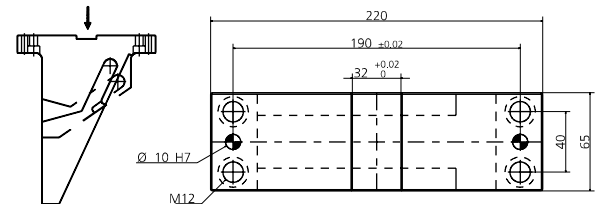

019 (9003) SENSORE / SENSOR / SENSOR



19 PATENT PENDING

MODELLO D'ORDINE / ORDER EXAMPLE / BESTELLBEISPIEL / MODÈLE DE COMMANDE

MODEL **0149.K580** INCLINATION **+10°** OPTION CODE **9003.0002**