

0149.K2A0 - CAM ROLLER K2A0

FORZA INIZIALE DI ESTRAZIONE / INITIAL EXTRACTION FORCE **170 daN** SFORZO MAX TRANCIO **7600 daN**
 RÜCKZUGSKRAFT / FORCE INITIALE D'EXTRACTION
 FORZA FINALE DI ESTRAZIONE / FINAL FORCE OF EXTRACTION **360 daN** CUTTING MAX FORCE
 ENDKRAFT DER EXTRAKTION / FORCE FINALE D'EXTRACTION MAXIMALE SCHNITTKRAFT
 EFFORT MAXI DÉCOUPE

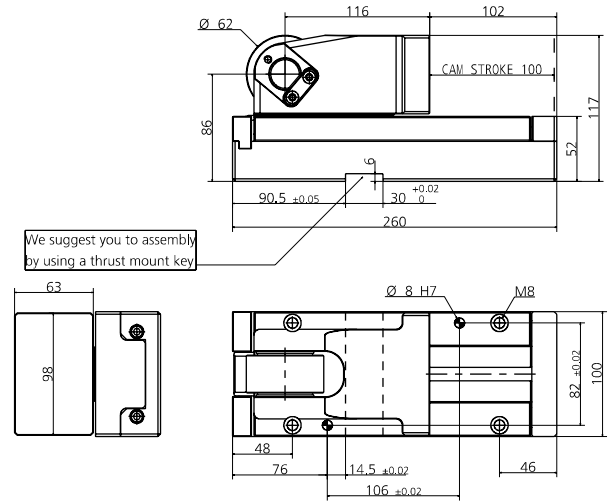
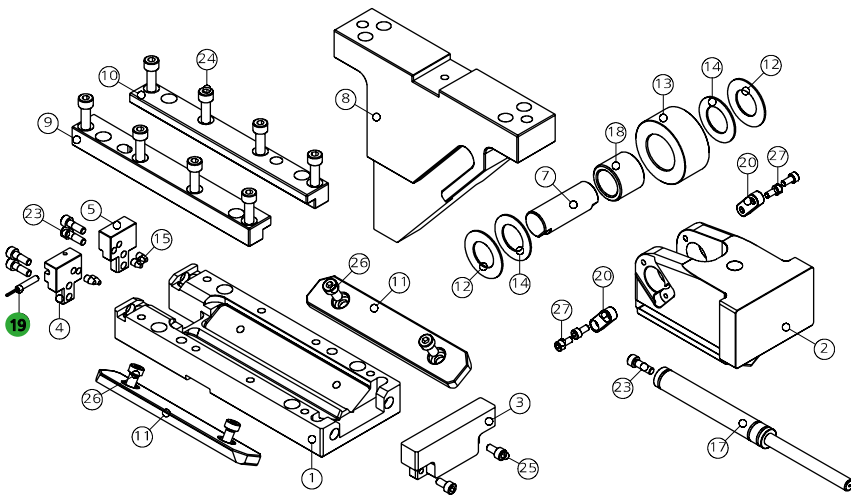

POS.	CODE	DESCRIPTION	Q.TY
001	8000.0049.02A0	CORPO CAMMA / CAM BODY / GRUNDGEHÄUSE	1
002	8007.0049.0200	SLITTA / SLIDER / LAGERKEIL	1
003	8088.0049.0200.001	PIASTRINA / PLATE / PLATTE	1
004	8088.0049.0200.002	PIASTRINA / PLATE / PLATTE	1
005	8088.0049.0200.003	PIASTRINA / PLATE / PLATTE	1
007	8005.0670.0517.250.001	PERNO / PIN / STIFT	1
008	8090.0203.A080.000	CUNEO / WEDGE / DRUCKSTÜCK 0	1*OPTION
008	8090.0203.A080.605	CUNEO / WEDGE / DRUCKSTÜCK +5	1*OPTION
008	8090.0203.A080.610	CUNEO / WEDGE / DRUCKSTÜCK +10	1*OPTION
008	8090.0203.A080.615	CUNEO / WEDGE / DRUCKSTÜCK +15	1*OPTION
008	8090.0203.A080.705	CUNEO / WEDGE / DRUCKSTÜCK -5	1*OPTION
008	8090.0203.A080.710	CUNEO / WEDGE / DRUCKSTÜCK -10	1*OPTION
008	8090.0203.A080.715	CUNEO / WEDGE / DRUCKSTÜCK -15	1*OPTION
008	8090.0203.A080.720	CUNEO / WEDGE / DRUCKSTÜCK -20	1*OPTION
008	8090.0203.A080.725	CUNEO / WEDGE / DRUCKSTÜCK -25	1*OPTION
008	8090.0203.A080.730	CUNEO / WEDGE / DRUCKSTÜCK -30	1*OPTION
008	8090.0203.A080.735	CUNEO / WEDGE / DRUCKSTÜCK -35	1*OPTION
008	8090.0203.A080.740	CUNEO / WEDGE / DRUCKSTÜCK -40	1*OPTION
008	8090.0203.A080.745	CUNEO / WEDGE / DRUCKSTÜCK -45	1*OPTION
008	8090.0203.A080.750	CUNEO / WEDGE / DRUCKSTÜCK -50	1*OPTION
009	8086.2220.0280.200.001	GUIDA ANGOLARE / SIDE PLATE L / WINKELFÜHRUNG FÜHRUNGSSCHIENE	1
010	8086.2220.0280.200.002	GUIDA ANGOLARE / SIDE PLATE L / WINKELFÜHRUNG FÜHRUNGSSCHIENE	1
011	8012.1850.0340.100.001	PIASTRA DI SCORRIMENTO / WEAR PLATE / DRUCKPLATTE	2
012	8006.0215.0460.255.001	RONDELLA / WASHER / UNTERLEGSCHEIBE	2
013	8004.0620.0305.350.001	ROTELLA / ROLLER / ROLLE	1
014	9033.2644.015	RALLA / THRUST WASHER / DRUCKSCHEIBE	2
015	9020.06.10.E090	PUNTALINO / BUMP STOP / DRUCKSTÜCK	4
017	9000.0100.0019.001	CILINDRO AD AZOTO / NITROGEN CYLINDER / STICKSTOFFZYLINDER	1
018	9035.2535.300.001	BOCCOLA / BUSH / BÜCHSE	1
019	9003.0002	SENSORE DI SICUREZZA / SECURITY SENSOR / SENSOR FÜR SICHERHEIT	1*OPTION
020	8087.0350.0120.080.001	CHIAVETTA / KEY / SCHLÜSSEL	2
023	9007.06.020.129.1.4762	PUNTALINO / BUMP STOP / DRUCKSTÜCK	5
024	9007.08.025.129.1.4762	VITE / SCREW / SCHRAUBE M8X25	8
025	9007.06.012.129.1.4762	VITE / SCREW / SCHRAUBE M6X12	2
026	9007.08.016.129.1.9327	VITE / SCREW / SCHRAUBE M8X16	4
027	9007.05.012.129.1.4762	VITE / SCREW / SCHRAUBE M5X12	4

POSSIBILI INCLINAZIONI / POSSIBLE INCLINATIONS / MÖGLICHE NEIGUNGEN

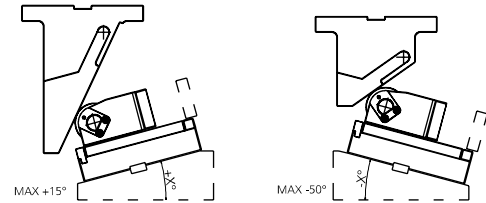

008 (8090) CUNEO / WEDGE / DRUCKSTÜCK

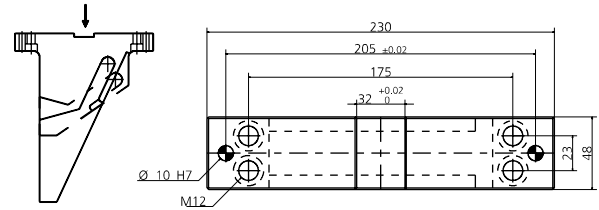

019 (9003) SENSORE / SENSOR / SENSOR



19 PATENT PENDING

MODELLO D'ORDINE / ORDER EXAMPLE / BESTELLBEISPIEL / MODÈLE DE COMMANDE

MODEL **0149.K2A0** INCLINATION **+10°** OPTION CODE **9003.0002**