

0146.0404 - CAM MASC COMPACT400 S48

FORZA INIZIALE DI ESTRAZIONE / INITIAL EXTRACTION FORCE

400 daN

SFORZO MAX TRANCIO

8000 daN

RÜCKZUGSKRAFT / FORCE INITIALE D'EXTRACTION

CUTTING MAX FORCE

FORZA FINALE DI ESTRAZIONE / FINAL FORCE OF EXTRACTION

450 daN

MAXIMALE SCHNITTKRAFT

ENDKRAFT DER EXTRACTION / FORCE FINALE D'EXTRACTION

EFFORT MAXI DÉCOUPE

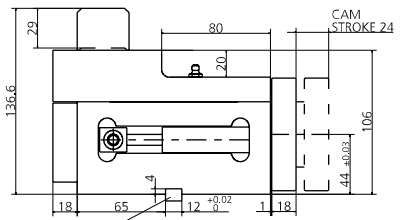
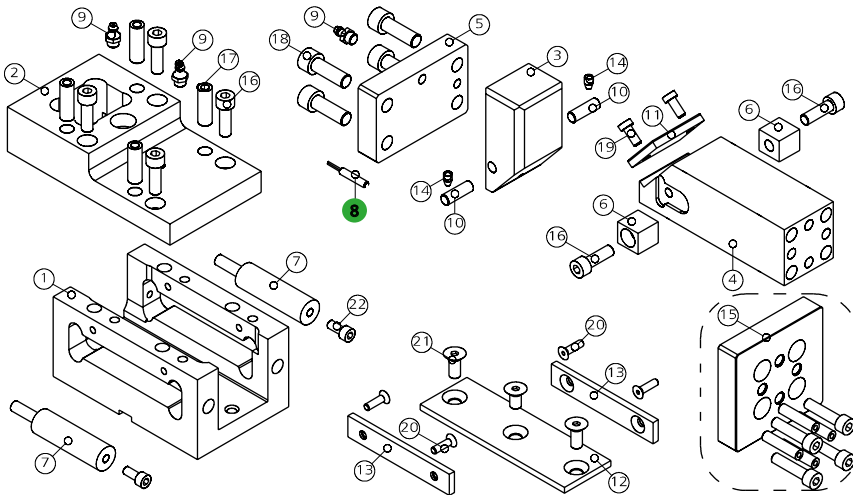

We suggest you to assembly by using a thrust mount key

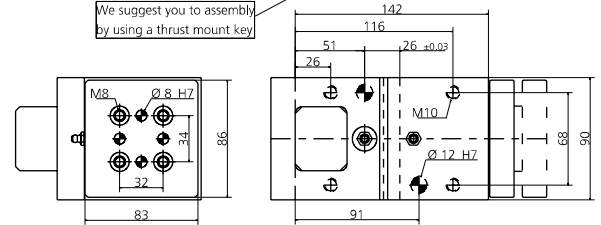

POS.	CODE	DESCRIPTION	Q.TY
001	8000.0046.0404	CORPO CAMMA / CAM BODY / GRUNDGEHÄUSE	1
002	8010.4546.0404	COPERCHIO / COVER / KOPFPLATTE	1
003	8008.4546.0405	CUNEO / WEDGE / DRUCKKEIL	1
004	8007.4546.0404	SLITTA / SLIDER / LAGE	1
005	8002.4546.0404	FLANGIA POSTERIORE / REAR FLANGE / HINTERER FLANSCH	1
006	8026.0300.0200.180.001	BLOCCHETTO REGGI MOLLA / SPRING HOLDER BLOCK / FEDERLAGERBLOCK	2
007	9000.0025.0019.007	CILINDRO AD AZOTO / NITROGEN CYLINDER / STICKSTOFFZYLINDER	2
008	9003.0002	SENSORE DI SICUREZZA / SECURITY SENSOR / SENSOR FÜR SICHERHEIT	1*OPTION
009	9006.002	INGRASSATORE / NIPPLE / SCHMIERUNG	3
010	8005.0250.0250.080.001	PERNO / PIN / STIFT	2
011	8012.0470.0380.060.001	PIASTRA DI SCORRIMENTO / SLIDING PAD / GLEITPLATTE	1
012	8012.1420.0460.050.001	PIASTRA DI SCORRIMENTO / SLIDING PAD / GLEITPLATTE	1
013	9012.1000.0180.050.001	PIASTRA DI SCORRIMENTO / SLIDING PAD / GLEITPLATTE	2
014	9020.06.10.E090	PUNTALINO / BUMP STOP / DRUCKSTÜCK	2
015	8014.4546.0404	KIT PORTA PUNZONE / KIT PUNCH HOLDER / KIT TRÄGERPLATTE	1*OPTION
016	9007.08.020.129.1.4762	VITE / SCREW / SCHRAUBE M8X20	6
017	9028.100.030.8735	SPINA CILINDRICA / DOWEL PIN / ZYLINDERSTIFT D10X30	4
018	9007.10.030.129.1.4762	VITE / SCREW / SCHRAUBE M10X30	4
019	9007.06.010.088.1.9327	VITE / SCREW / SCHRAUBE M6X10	2
020	9007.06.012.129.1.5933	VITE / SCREW / SCHRAUBE M6X12	4
021	9007.08.012.129.1.5933	VITE / SCREW / SCHRAUBE M8X12	3
022	9007.06.012.129.1.4762	VITE / SCREW / SCHRAUBE M6X12	2

POSSIBILI INCLINAZIONI / POSSIBLE INCLINATIONS / MÖGLICHE NEIGUNGEN

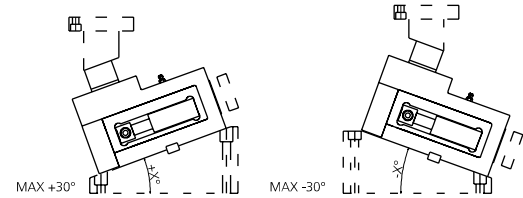

008 (9003) SENSORE / SENSOR / SENSOR



8 PATENT PENDING

MODELLO D'ORDINE / ORDER EXAMPLE / BESTELLBEISPIEL / MODÈLE DE COMMANDE

MODEL **0146.0404** OPTION CODE **8014.4546.0404**