

0145.0419 - CAM MASC400 S198

FORZA INIZIALE DI ESTRAZIONE / INITIAL EXTRACTION FORCE **400 daN** SFORZO MAX TRANCIO **8000 daN**
 RÜCKZUGSKRAFT / FORCE INITIALE D'EXTRACTION
 FORZA FINALE DI ESTRAZIONE / FINAL FORCE OF EXTRACTION **450 daN** CUTTING MAX FORCE
 ENDKRAFT DER EXTRACTION / FORCE FINALE D'EXTRACTION MAXIMALE SCHNITTKRAFT
 EFFORT MAXI DÉCOUPE

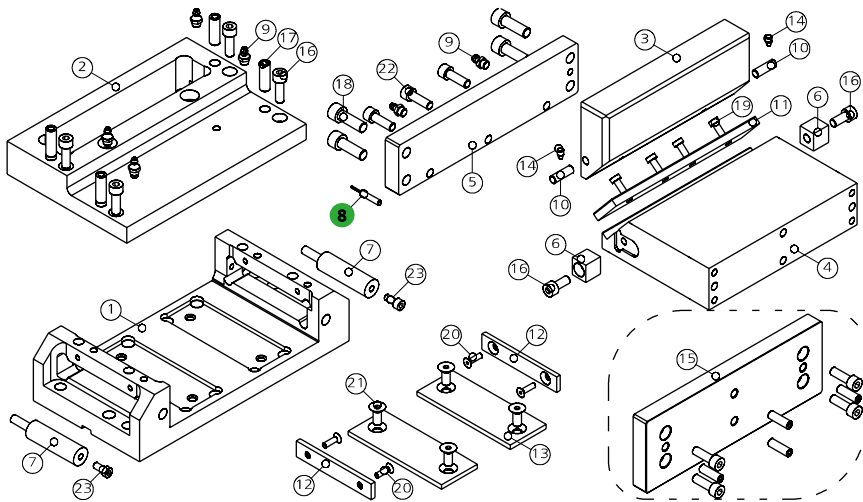

| POS. | CODE | DESCRIPTION | Q.TY |
|------|-------------------------------|--|----------|
| 001 | 8000.0045.0419 | CORPO CAMMA / CAM BODY / GRUNDGEHÄUSE | 1 |
| 002 | 8010.4546.0419 | COPERCHIO / COVER / KOPFPLATTE | 1 |
| 003 | 8008.4546.1920 | CUNEO / WEDGE / DRUCKKEIL | 1 |
| 004 | 8007.4546.0419 | SLITTA / SLIDER / LAGE | 1 |
| 005 | 8002.4546.0419 | FLANGIA POSTERIORE / REAR FLANGE / HINTERER FLANSCH | 1 |
| 006 | 8026.0300.0200.180.001 | BLOCCHETTO REGGI MOLLA / SPRING HOLDER BLOCK / FEDERLAGERBLOCK | 2 |
| 007 | 9000.0025.0019.007 | CILINDRO AD AZOTO / NITROGEN CYLINDER / STICKSTOFFZYLINDER | 2 |
| 008 | 9003.0002 | SENSORE DI SICUREZZA / SECURITY SENSOR / SENSOR FÜR SICHERHEIT | 1*OPTION |
| 009 | 9006.002 | INGRASSATORE / NIPPLE / SCHMIERUNG | 3 |
| 010 | 8005.0250.0250.080.001 | PERNO / PIN / STIFT | 2 |
| 011 | 8012.0950.0370.080.001 | PIASTRA DI SCORRIMENTO / SLIDING PAD / GLEITPLATTE | 2 |
| 012 | 9012.1000.0180.050.001 | PIASTRA DI SCORRIMENTO / SLIDING PAD / GLEITPLATTE | 2 |
| 013 | 9012.1250.0480.050.001 | PIASTRA DI SCORRIMENTO / SLIDING PAD / GLEITPLATTE | 2 |
| 014 | 9020.06.10.E090 | PUNTALINO / BUMP STOP / DRUCKSTÜCK | 2 |
| 015 | 8014.4546.0419 | KIT PORTA PUNZONE / KIT PUNCH HOLDER / KIT TRÄGERPLATTE | 1*OPTION |
| 016 | 9007.08.020.129.1.4762 | VITE / SCREW / SCHRAUBE M8X20 | 6 |
| 017 | 9028.100.030.8735 | SPINA CILINDRICA / DOWEL PIN / ZYLINDERSTIFT D10X30 | 4 |
| 018 | 9007.10.030.129.1.4762 | VITE / SCREW / SCHRAUBE M10X30 | 4 |
| 019 | 9007.06.010.088.1.9327 | VITE / SCREW / SCHRAUBE M6X10 | 4 |
| 020 | 9007.06.012.129.1.5933 | VITE / SCREW / SCHRAUBE M6X12 | 4 |
| 021 | 9007.08.012.129.1.5933 | VITE / SCREW / SCHRAUBE M8X12 | 6 |
| 022 | 9007.08.030.129.1.4762 | VITE / SCREW / SCHRAUBE M8X30 | 3 |
| 023 | 9007.06.012.129.1.4762 | VITE / SCREW / SCHRAUBE M6X12 | 2 |

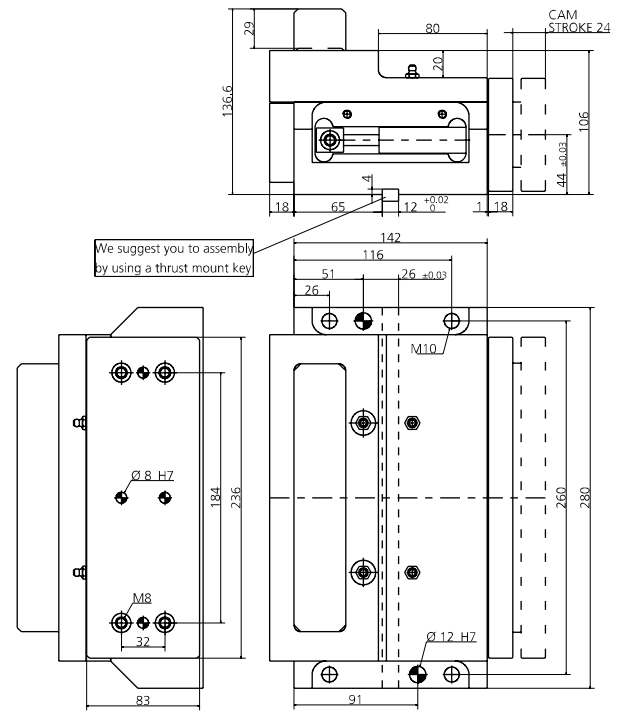

POSSIBILI INCLINAZIONI / POSSIBLE INCLINATIONS / MÖGLICHE NEIGUNGEN

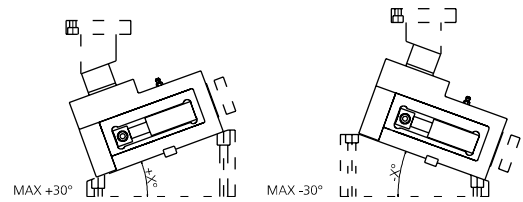

008 (9003) SENSORE / SENSOR / SENSOR



8 PATENT PENDING

MODELLO D'ORDINE / ORDER EXAMPLE / BESTELLBEISPIEL / MODÈLE DE COMMANDE

MODEL **0145.0419** OPTION CODE **8014.4546.0419**