

0144.0600 - CAM MAS600

FORZA INIZIALE DI ESTRAZIONE / INITIAL EXTRACTION FORCE **600 daN**
RÜCKZUGSKRAFT / FORCE INITIALE D'EXTRACTION

SFORZO MAX TRANCIO **13000 daN**

FORZA FINALE DI ESTRAZIONE / FINAL FORCE OF EXTRACTION **880 daN**
ENDKRAFT DER EXTRACTION / FORCE FINALE D'EXTRACTION

CUTTING MAX FORCE
MAXIMALE SCHNITTKRAFT
EFFORT MAXI DÉCOUPE

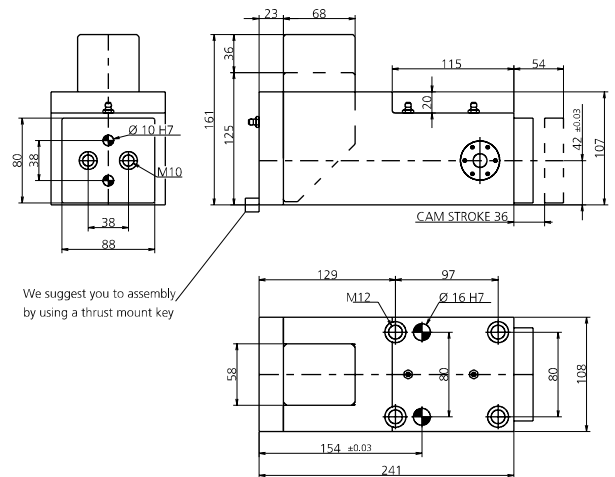
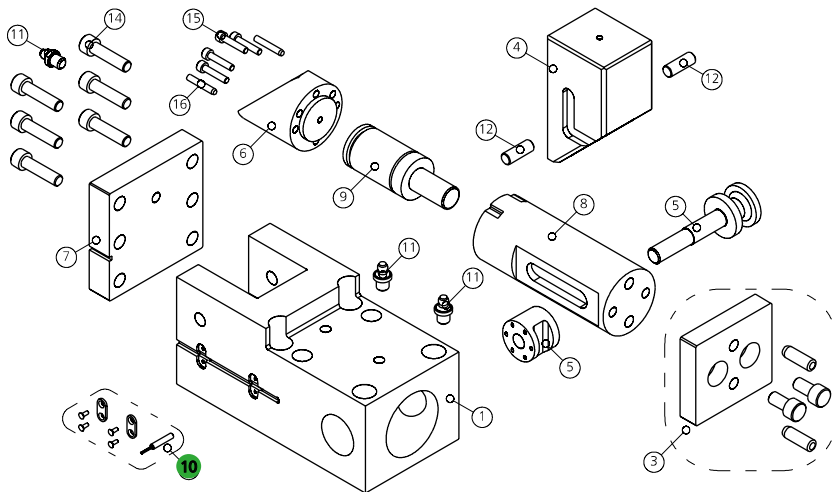

POS.	CODE	DESCRIPTION	Q.TY
001	8000.0044.0600	CORPO CAMMA / CAM BODY / GRUNDGEHÄUSE	1
003	8014.4244.0600	KIT PORTA PUNZONE / KIT PUNCH HOLDER / KIT TRÄGERPLATTE	1*OPTION
004	8008.0044.0600	CUNEO / WEDGE / DRUCKKEIL	1
005	8017.4244.0600	PERNO DI GUIDA / GUIDE PIN / FÜHRUNGSTIFTE	1
006	8007.0044.0600	SLITTA / SLIDER / LAGERKEIL	1
007	8002.0044.0600	FLANGIA POSTERIORE / REAR FLANGE	1
008	8018.1500.1275.600.001	PERNO CENTRALE / CENTRAL PIN / HAUPTSTIFT	1
009	9000.0038.0038.001	CILINDRO AD AZOTO / NITROGEN CYLINDER / STICKSTOFFZYLINDER	1
010	8107.0144.0600.001	KIT SENSORE DI SICUREZZA / SECURITY SENSOR KIT / KIT SENSOR FÜR SICHERHEIT	1*OPTION
011	9006.003	INGRASSATORE / NIPPLE / SCHMIERUNG	3
012	8005.0295.0295.120.001	PERNO / PIN / STIFT	2
014	9007.12.040.129.1.4762	VITE / SCREW / SCHRAUBE M12X40	6
015	9007.06.025.129.1.4762	VITE / SCREW / SCHRAUBE M6X25	4
016	9028.060.020.8735	SPINA CILINDRICA / DOWEL PIN / ZYLINDERSTIFT D6X20	2

POSSIBILI INCLINAZIONI / POSSIBLE INCLINATIONS / MÖGLICHE NEIGUNGEN

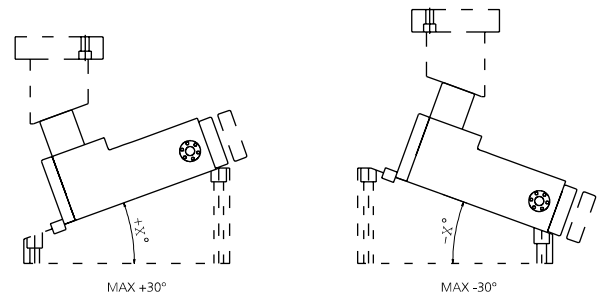

010 (8107) SENSORE / SENSOR / SENSOR



10 PATENT PENDING

MODELLO D'ORDINE / ORDER EXAMPLE / BESTELLBEISPIEL / MODÈLE DE COMMANDE

MODEL **0144.0600** OPTION CODE **8014.4244.0600**