

# 0147.3303 - CAM MASE300-63

FORZA INIZIALE DI ESTRAZIONE / INITIAL EXTRACTION FORCE **3300 daN**

RÜCKZUGSKRAFT / FORCE INITIALE D'EXTRACTION

FORZA FINALE DI ESTRAZIONE / FINAL FORCE OF EXTRACTION **7250 daN**

ENDKRAFT DER EXTRACTION / FORCE FINALE D'EXTRACTION

SFORZO MAX TRANCIO **30000 daN**

CUTTING MAX FORCE  
MAXIMALE SCHNITTKRAFT  
EFFORT MAXI DÉCOUPE

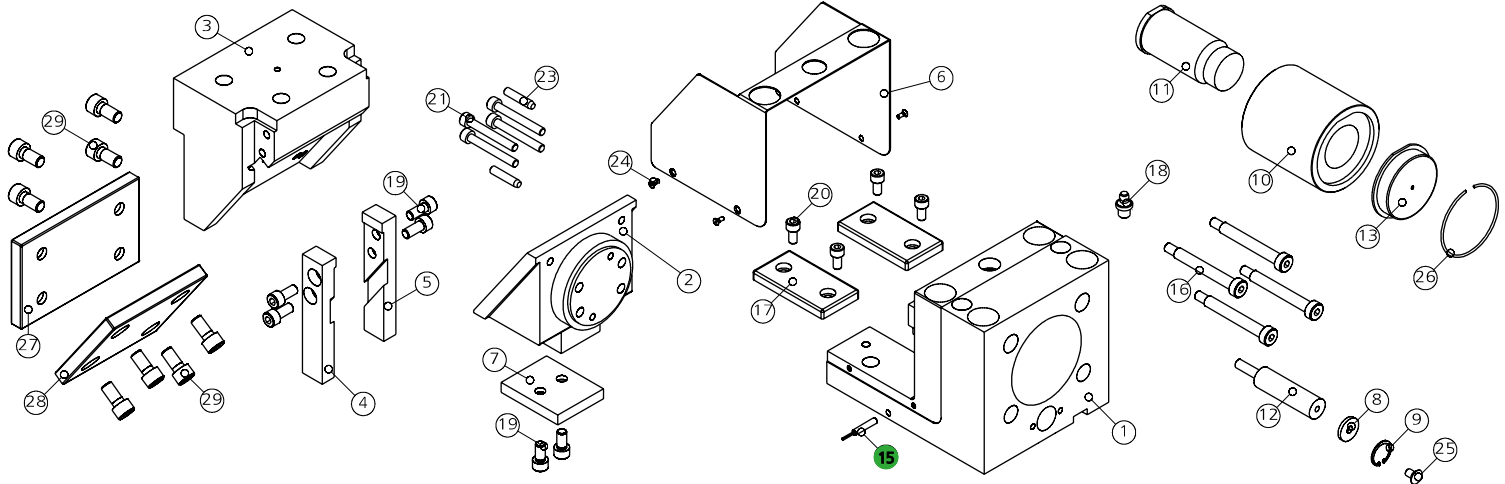

POS.	CODE	DESCRIPTION	Q.TY
001	<b>8000.0047.3300</b>	CORPO CAMMA / CAM BODY / GRUNDGEHÄUSE	1
002	<b>8111.0047.0033.00.001</b>	SLITTA / SLIDER / LAGERKEIL 0°	1*CHOOSE
002	<b>8111.0047.0033.05.001</b>	SLITTA / SLIDER / LAGERKEIL +5°	1*CHOOSE
002	<b>8111.0047.0033.10.001</b>	SLITTA / SLIDER / LAGERKEIL +10°	1*CHOOSE
002	<b>8111.0047.0033.15.001</b>	SLITTA / SLIDER / LAGERKEIL +15°	1*CHOOSE
003	<b>8116.0047.0033.00.001</b>	CUNEO / WEDGE / DRUCKSTÜCK 0°	1*CHOOSE
003	<b>8116.0047.0033.10.002</b>	CUNEO / WEDGE / DRUCKSTÜCK +10°	1*CHOOSE
003	<b>8116.0047.0033.05.001</b>	CUNEO / WEDGE / DRUCKSTÜCK -5°	1*CHOOSE
003	<b>8116.0047.0033.10.001</b>	CUNEO / WEDGE / DRUCKSTÜCK -10°	1*CHOOSE
003	<b>8116.0047.0033.15.001</b>	CUNEO / WEDGE / DRUCKSTÜCK -15°	1*CHOOSE
004	<b>8115.0047.0033.00.001</b>	STAFFA DI AGGANCIAMENTO / BRACKET ATTACHMENTS / BRACKETBEFESTIGUNG 0°	1*CHOOSE
004	<b>8115.0047.0033.10.003</b>	STAFFA DI AGGANCIAMENTO / BRACKET ATTACHMENTS / BRACKETBEFESTIGUNG +10°	1*CHOOSE
004	<b>8115.0047.0033.05.001</b>	STAFFA DI AGGANCIAMENTO / BRACKET ATTACHMENTS / BRACKETBEFESTIGUNG -5°	1*CHOOSE
004	<b>8115.0047.0033.10.001</b>	STAFFA DI AGGANCIAMENTO / BRACKET ATTACHMENTS / BRACKETBEFESTIGUNG -10°	1*CHOOSE
004	<b>8115.0047.0033.15.001</b>	STAFFA DI AGGANCIAMENTO / BRACKET ATTACHMENTS / BRACKETBEFESTIGUNG -15°	1*CHOOSE
005	<b>8115.0047.0033.00.002</b>	STAFFA DI AGGANCIAMENTO / BRACKET ATTACHMENTS / BRACKETBEFESTIGUNG 0°	1*CHOOSE
005	<b>8115.0047.0033.10.004</b>	STAFFA DI AGGANCIAMENTO / BRACKET ATTACHMENTS / BRACKETBEFESTIGUNG +10°	1*CHOOSE
005	<b>8115.0047.0033.05.002</b>	STAFFA DI AGGANCIAMENTO / BRACKET ATTACHMENTS / BRACKETBEFESTIGUNG -5°	1*CHOOSE
005	<b>8115.0047.0033.10.002</b>	STAFFA DI AGGANCIAMENTO / BRACKET ATTACHMENTS / BRACKETBEFESTIGUNG -10°	1*CHOOSE
005	<b>8115.0047.0033.15.002</b>	STAFFA DI AGGANCIAMENTO / BRACKET ATTACHMENTS / BRACKETBEFESTIGUNG -15°	1*CHOOSE
006	<b>8010.0047.3300</b>	COPERCHIO / COVER / KOPFPLATTE	1
007	<b>8011.0047.3300</b>	PIASTRA / PLATE / PLATTE	1
008	<b>8006.0130.0218.065.001</b>	RONDELLA / WASHER / UNTERLEGSCHEIBE	1
009	<b>9004.2220.001</b>	SEEGER / SEEGER / SEEGERRING	1
010	<b>9030.063.001</b>	CILINDRO SPECIALE / SPECIAL CYLINDER / SPEZIALZYLINDER	1
011	<b>9090.3JBM2.630.090</b>	PUNZONE SBOZZATO TC CON ESPULSORE / HEADED PUNCH WITH EJECTOR / SCHNEIDSTEMPEL MIT ABSTOSSER 63 90	1*OPTION
011	<b>9090.3JBM2.630.100</b>	PUNZONE SBOZZATO TC CON ESPULSORE / HEADED PUNCH WITH EJECTOR / SCHNEIDSTEMPEL MIT ABSTOSSER 63 100	1*OPTION

POS.	CODE	DESCRIPTION	Q.TY
011	<b>093J_M2.630.090</b>	PUNZONE TC CON ESPULSORE / HEADED PUNCH WITH EJECTOR / SCHNEIDSTEMPEL MIT ABSTOSSER 63 90	1*OPTION
011	<b>093J_M2.630.100</b>	PUNZONE TC CON ESPULSORE / HEADED PUNCH WITH EJECTOR / SCHNEIDSTEMPEL MIT ABSTOSSER 63 100	1*OPTION
012	<b>9000.0025.0019.004</b>	CILINDRO DI RITORNO / RETURN CYLINDER / RÜCK ZYLINDER	1
013	<b>9016.090.063.001</b>	PREMILAMIERA CORTO / SHORT BLANKHOLDER / KURZ BLECHHALTER 90MM	1*CHOOSE
013	<b>9016.090.063.002</b>	PREMILAMIERA LUNGO / LONG BLANKHOLDER / LANG BLECHHALTER 90MM	1*CHOOSE
013	<b>9016.100.063.001</b>	PREMILAMIERA CORTO / SHORT BLANKHOLDER / KURZ BLECHHALTER 100MM	1*CHOOSE
013	<b>9016.100.063.002</b>	PREMILAMIERA LUNGO / LONG BLANKHOLDER / LANG BLECHHALTER 100MM	1*CHOOSE
013	<b>8016.090.063.001</b>	PREMILAMIERA CORTO / SHORT BLANKHOLDER / KURZ BLECHHALTER 90MM	1*OPTION
013	<b>8016.090.063.002</b>	PREMILAMIERA LUNGO / LONG BLANKHOLDER / LANG BLECHHALTER 90MM	1*OPTION
013	<b>8016.100.063.001</b>	PREMILAMIERA CORTO / SHORT BLANKHOLDER / KURZ BLECHHALTER 100MM	1*OPTION
013	<b>8016.100.063.002</b>	PREMILAMIERA LUNGO / LONG BLANKHOLDER / LANG BLECHHALTER 100MM	1*OPTION
015	<b>9003.0002</b>	SENSORE DI SICUREZZA / SECURITY SENSOR / SENSOR FÜR SICHERHEIT	1*OPTION
016	<b>9008.1012.090</b>	VITE A COLLETO / SHOULDER SCREW / ANSATZSCHRAUBE	4
017	<b>8012.0950.0500.100.001</b>	PIASTRA DI SCORRIMENTO / WEAR PLATE / DRUCKPLATTE	2
018	<b>9006.002</b>	INGRASSATORE / NIPPLES / SCHMIERUNG	1
019	<b>9007.08.016.129.1.4762</b>	VITE / SCREW / SCHRAUBE M8X16	6
020	<b>9007.08.012.088.1.9327</b>	VITE / SCREW / SCHRAUBE M8X12	4
021	<b>9007.08.050.129.1.4762</b>	VITE / SCREW / SCHRAUBE M8X50	8
023	<b>9028.06.020.8735</b>	SPINA CILINDRICA / DOWEL PIN / ZYLINDERSTIFT D6X20	2
024	<b>9007.03.005.048.1.7687</b>	VITE / SCREW / SCHRAUBE M3X5	4
025	<b>9007.06.014.129.1.5933</b>	VITE / SCREW / SCHRAUBE M6X14	1
026	<b>9004.2980.001</b>	SEEGER / SEEGER / SEEGERRING	1
027	<b>8012.1960.0850.120.001</b>	PIASTRA DI SCORRIMENTO / WEAR PLATE / DRUCKPLATTE	1
028	<b>8012.1670.1050.120.001</b>	PIASTRA DI SCORRIMENTO / WEAR PLATE / DRUCKPLATTE	1
029	<b>9007.10.020.109.1.9327</b>	VITE / SCREW / SCHRAUBE M10X20	8

FORZA INIZIALE DI ESTRAZIONE / INITIAL EXTRACTION FORCE **3300 daN**  
 RÜCKZUGSKRAFT / FORCE INITIALE D'EXTRACTION  
 FORZA FINALE DI ESTRAZIONE / FINAL FORCE OF EXTRACTION **7250 daN**  
 ENDKRAFT DER EXTRAKTION / FORCE FINALE D'EXTRACTION

SFORZO MAX TRANCIO **30000 daN**  
 CUTTING MAX FORCE  
 MAXIMALE SCHNITTKRAFT  
 EFFORT MAXI DÉCOUPE

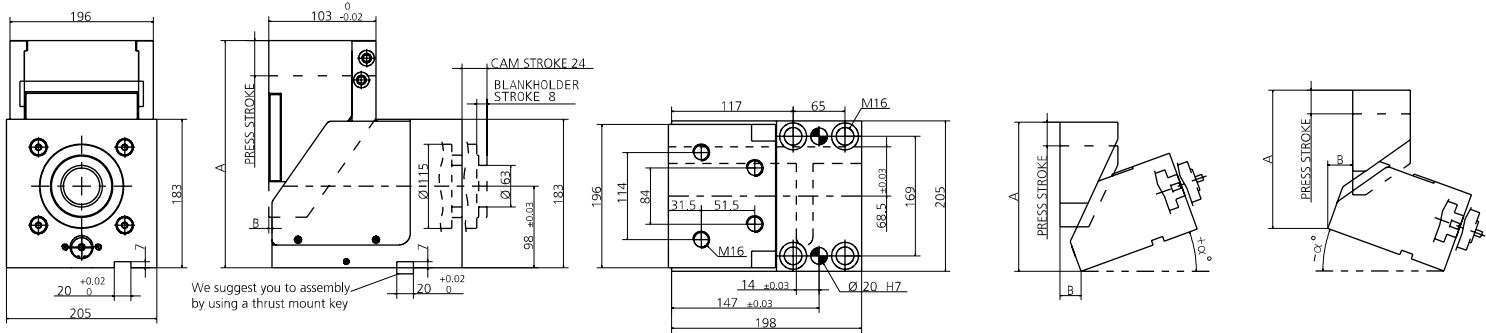

$\alpha^\circ$	PRESS STROKE	A	B
0°	34.1	248.78	3
+5°	32.05	247.2	20.75
+10°	29.6	257.18	37.51
+15°	26.9	257.46	54.25
-5°	30.6	242.78	8
-10°	27.8	236.78	9
-15°	25.65	229.78	22

\* PER INCLINAZIONI FUORI STANDARD RIVOLGERSI ALL'UFFICIO TECNICO NEWSTARK / \* FOR NON-STANDARD INCLINATIONS, PLEASE CONTACT NEWSTARK TECHNICAL OFFICE.  
 / \* FÜR NICHT STANDARDMÄSSIGE NEIGUNGEN WENDEN SIE SICH BITTE AN DAS TECHNISCHE BÜRO VON NEWSTARK

**0011 (9090) PUNZONE SBOZZATO / BLANK PUNCH / ROHLING SCHNEIDSTEMPEL ISO8020**

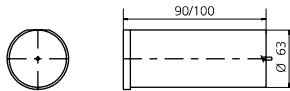

**013 (9016) PREMILAMIERA SBOZZATO / BLANK-BLANKHOLDER / ROHLING BLECHHALTER**

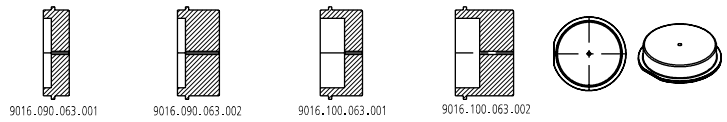

**011 (093J\_) PUNZONE SAGOMATO / SHAPED PUNCH / GEFORMT SCHNEIDSTEMPEL ISO8020**

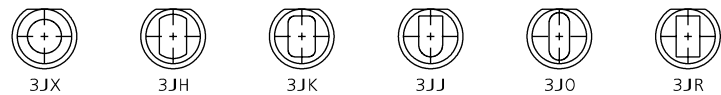

**013 (8016) PREMILAMIERA SAGOMATO / SHAPED BLANKHOLDER / GEFORMT BLECHHALTER (OPTION)**

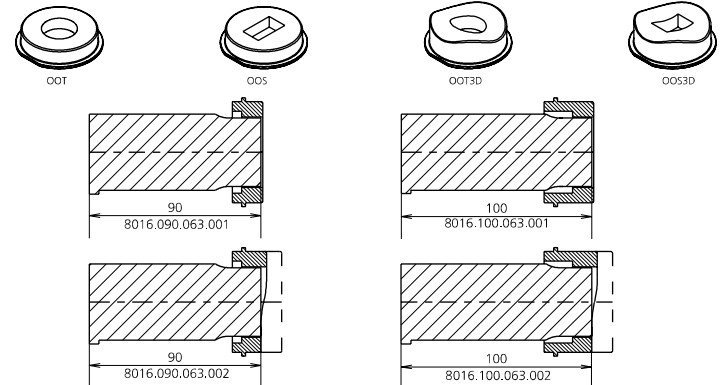

**015 (9003) SENSORE / SENSOR / SENSOR**



**15 PATENT PENDING**